

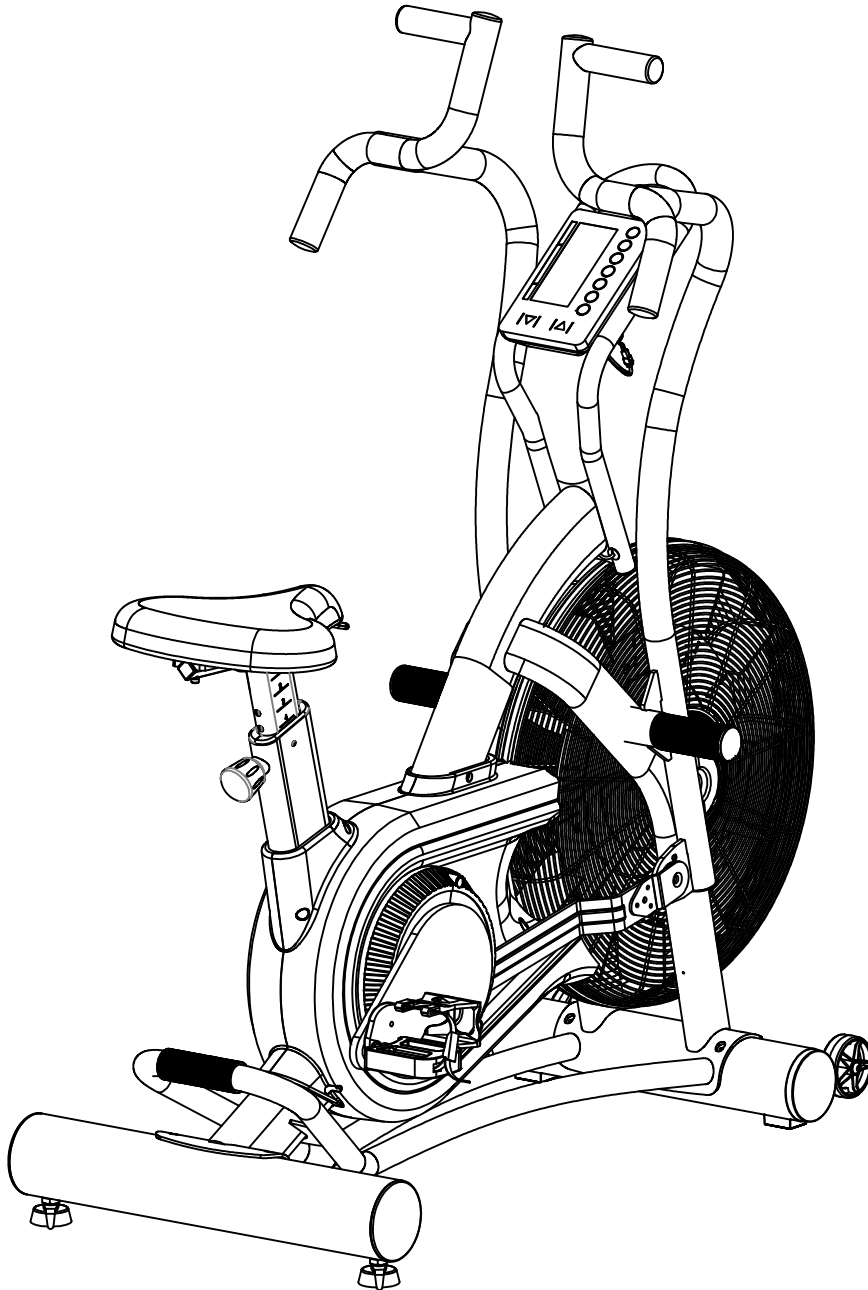

AirRaid Bike Owner's Manual



**PLEASE READ THIS INSTRUCTION MANUAL
BEFORE YOU BEGIN ASSEMBLY**



contents

safety information	03
customer support	04
assembly instructions	05
bike features explained	12
user instructions	13
- quick start	
- button functions	
- console display and feedback	
- using workout programs	
how to take care of your cycle	16
troubleshooting	16
exercising with your cycle	17
exploded diagrams and parts list	18

Safety Information

PLEASE READ THIS INSTRUCTION MANUAL BEFORE YOU BEGIN ASSEMBLY. GREAT CARE HAS BEEN TAKEN TO DESIGN THESE INSTRUCTIONS AND FOLLOWING THEM WILL HELP YOU WITH QUICKER ASSEMBLY AND MINIMISE THE RISK OF INJURY

YOU ARE RESPONSIBLE FOR YOUR OWN SAFETY - THIS LIST IS NOT EXHAUSTIVE.

- Always assemble and operate the product on a level surface
- Always use the product on a level surface, ensure that the product is stable before use.
- Always ensure that the equipment has adequate space on each side and front (the back can be near to a wall).
- Ensure that the seat height is adjusted correctly - you should be stable and balanced whilst on the saddle.
- Adjust the seat height to ensure that you have a good downward pedal stroke without overstretching, don't compromise your balance.
- Try to ensure that your back is straight whilst exercising, especially for long periods
- The safety level of this equipment can only be maintained if it is regularly examined for wear and tear
- Replace defective components immediately, and/or keep the equipment out of use until it is repaired.
- Use only the adjustment settings as described in the instructions. Always use the correct adjustment pin/fixing.
- Always check that any pins / fixings are tight and secure before use and / or after adjustment.
- Never leave any adjustment devices projecting from the product.
- Always consult your doctor before undertaking any exercise program.
- Always wear suitable clothing and footwear
e.g. tracksuit / shorts / training shoes
- Remove all personal jewellery before exercising.

It is important that you keep these instructions for future reference.

Care & Maintenance

- Always place the equipment in a dry environment.
- Use a warm, damp cloth to keep the product clean.
- No wet cleaning of electrical components, unplug before any care and maintenance
- The safety level of the equipment can be maintained only if it is regularly examined for damage and wear. This includes any ropes, pulleys, nuts, bolts, moving parts, bushes, chains, wheels, bearings & connection points etc.
- Ensure that you inspect the product regularly - at least once a week is recommended.
- Ensure that all fixings are tight before use.
- Always replace damaged / worn components with original parts from the manufacturer.

Protect the environment by not disposing of this product with household waste. Check your local authority for recycling advice and facilities (Europe only).



Customer Support

Should you require any assistance regarding this product please gather the following information, and then contact us using the details below:

1. Serial no. - this can be found on the sticker below, located as indicated. For future reference, please write down your serial number in the space provided below.
2. Original purchase date
3. Place of purchase
4. Information about the place and condition of use
5. Precise description of the issue/defect

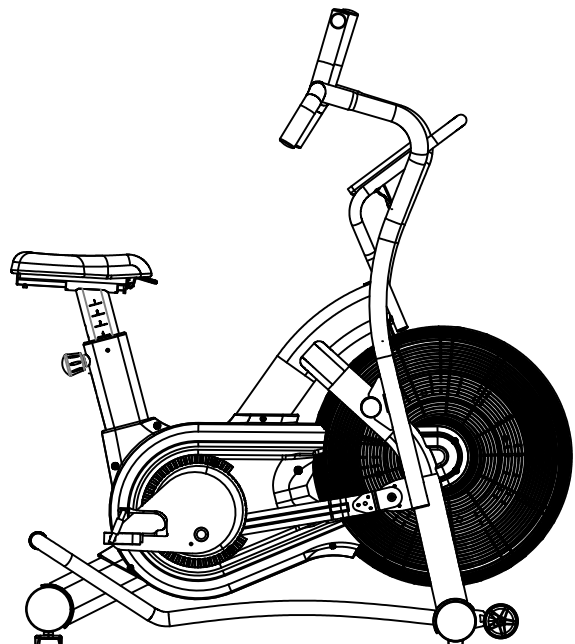

Assembly Instruction

Before you start

- 1. Prepare your work area** - it is important you assemble the product in a clean and uncluttered space.
- 2. Work with a friend** - we recommend you have someone assist you with the assembly as some of the components are quite heavy.
- 3. Open the carton** - checking any warnings on the carton and make sure you have it the right way up.
- 4. Unpack the carton** - Make sure you have the following parts:

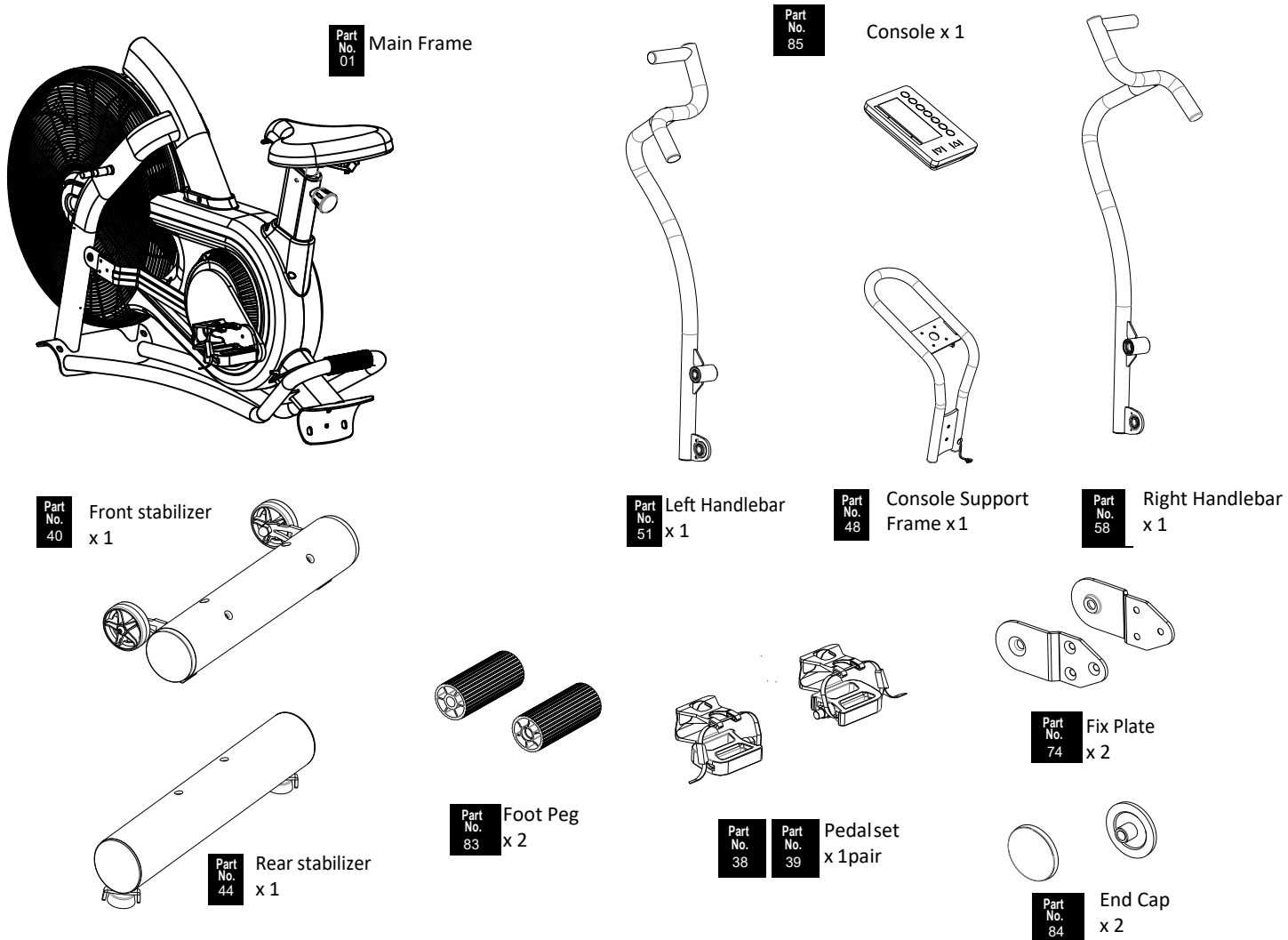

Fixings

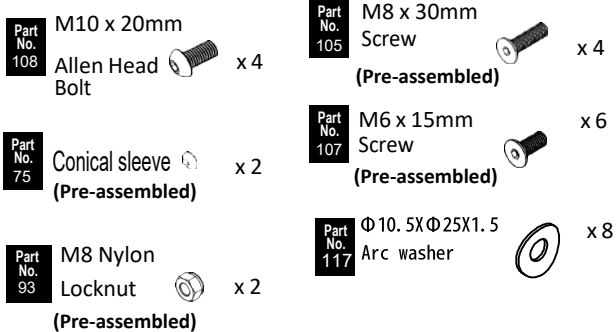

Tools and Consumables

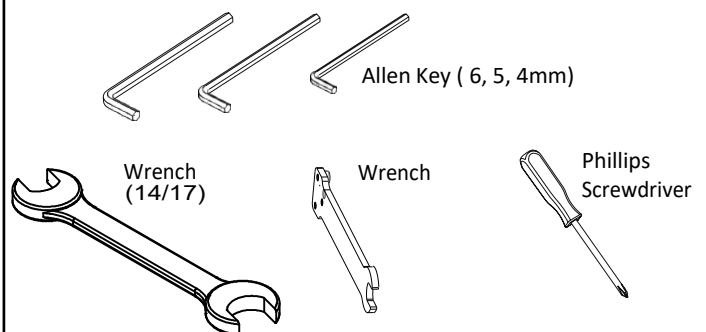

1. Attach the Front Stabilizer

1-1. Remove the cardboard tube from the front end stabilizer bracket

- Loosen the two **M10 x 20mm Allen Head Bolt (108)** from the cardboard tube and remove the cardboard tube.
- The cardboard tube is used for packaging protection purposes, which won't be used again during the assembly.

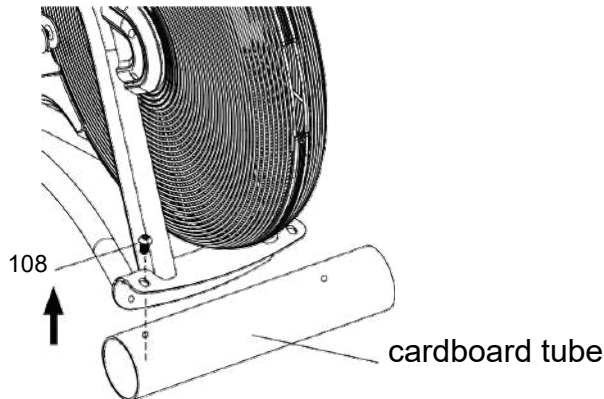

FIXINGS:



TOOLS:



1-2. Attach the Front Stabilizer

- Attach the **Front Stabilizer (40)** to the **Main Frame (01)** with four **M10 x 20mm Allen Head Bolt(108)** and $\Phi 10.5 \times \Phi 25 \times 1.5$ Arc washer (117), then tighten these bolts and washers with the 6mm Allen Key.

Be sure to fit the parts in the same order as the diagrams shown.

Make sure the bolts are fully tightened with the allen key.

Make sure the moving wheels on the front stabiliser are facing outward after assembly.

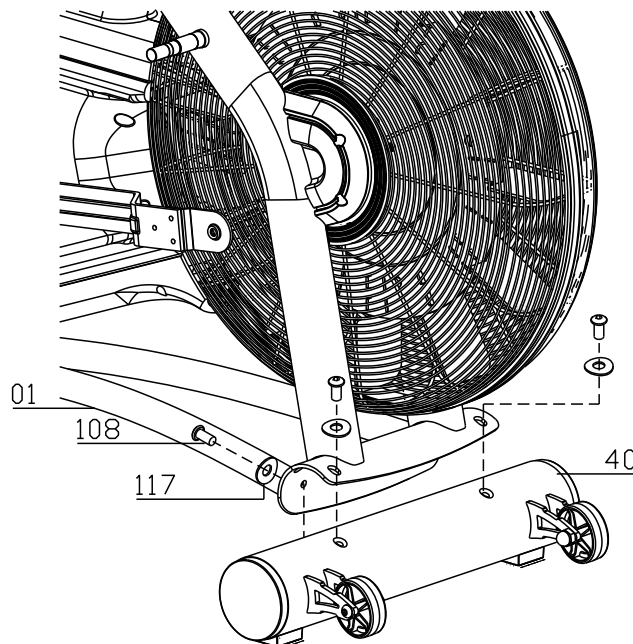

FIXINGS:



TOOLS:

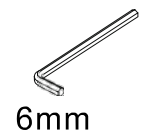

2. Attach the Rear Stabilizer

2-1. Remove the cardboard tube from the rear end stabilizer bracket

- Loosen the two **M10 x 20mm Allen Head Bolt (108)** from the cardboard tube and remove the cardboard tube.
- The cardboard tube is used for packaging protection purposes, which won't be used again during the assembly.

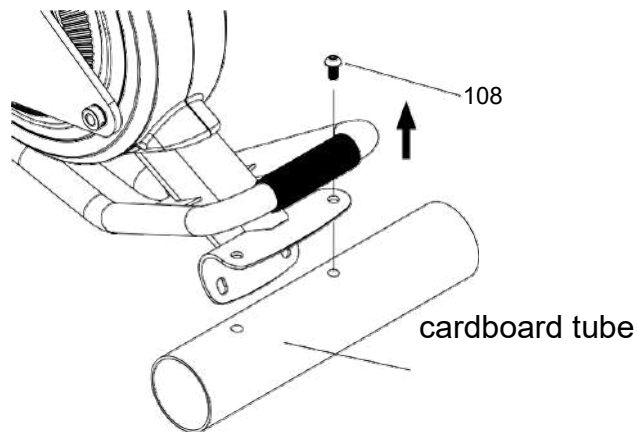

FIXINGS:



TOOLS:



2-2. Attach the Rear Stabilizer

- Attach the **Rear Stabilizer (44)** to the **Main Frame (01)** with four **M10 x 20mm Allen Head Bolt(108)** and $\Phi 10.5 \times \Phi 25 \times 1.5$ Arc washer (117), then tighten these bolts and washers with the 6mm Allen Key..

Be sure to fit the parts in the same order as the diagrams shown.

Make sure the bolts are fully tightened with the allen key.

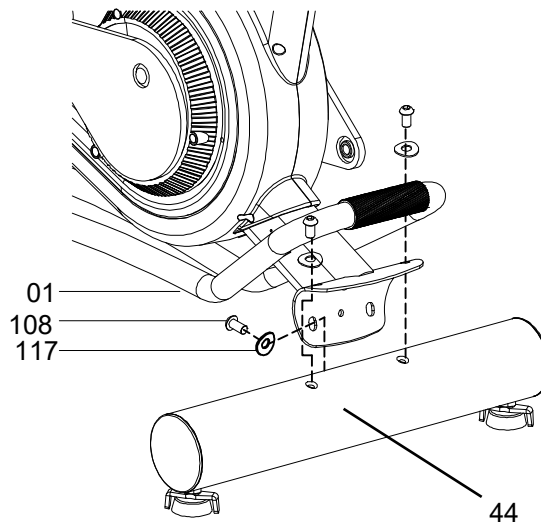

FIXINGS:



TOOLS:



3. Attach the Dual Action Handlebars

3-1. Attach the Left Dual Action Handlebar

- Slide the **left Dual Action Handlebar (51)** onto the pivot axle carefully.
- Install the **Foot Peg (83)** by screwing it on, and Tighten it with the wrench as shown.
- Attach the **End Cap (84)** onto the **Foot Peg (83)**

Be sure to fit the parts in the same order as the diagrams shown.

Make sure the foot peg is fully tightened with the allen key.

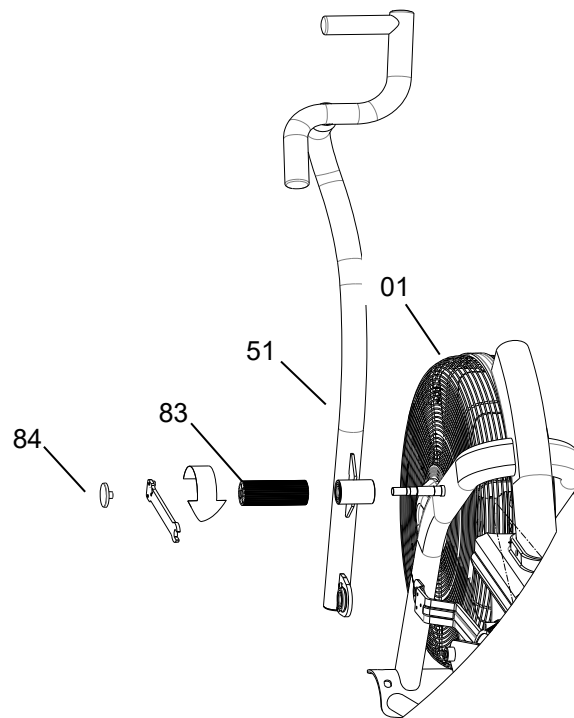

TOOLS:

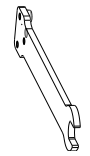

Wrench

3-2. Install the Fix Plate & Linkage Bar

- Connect the **left Dual Action Handlebar(51)** and **Linkage Bar with Fix Plate (74), Disc Spacer(75), M8x30mm Screw(105)** and **M8 Nylon Locknut (93)** and tighten with 5mm Allen Key & 14/17 Wrench.
- Doubly secure the **Fix Plate (74)** to the Linkage Bar with three **M6x15mm (107)** and secure with 4mm Allen Key.

Be sure to fit the parts in the same order as the diagrams shown.

Make sure the screws are fully tightened with the allen key.

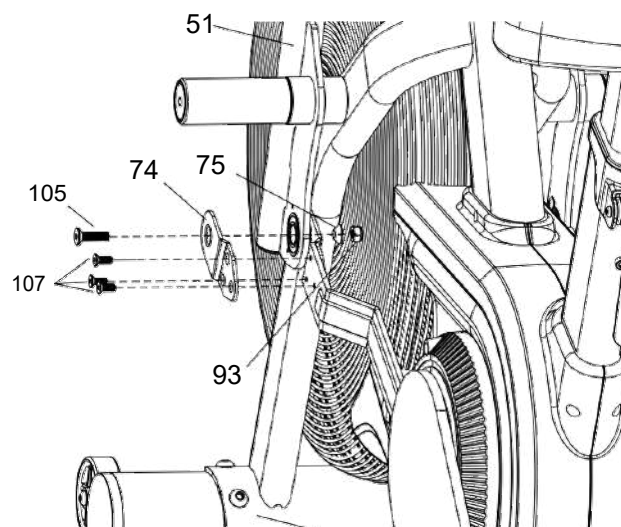

FIXINGS:



x 1



x 1



x 1



x 3

TOOLS:

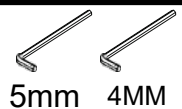

5mm 4MM



Wrench
(14/17)

3-3. Attach the Right Dual Action Handlebar

- Slide the **right Dual Action Handlebar (58)** onto the pivot axle carefully.
- Install the **Foot Peg (83)** by screwing it on, and Tighten it with the wrench as shown.
- Attach the **End Cap (84)** onto the **Foot Peg (83)**.

Be sure to fit the parts in the same order as the diagrams shown.

Make sure the foot peg is fully tightened with the allen key.

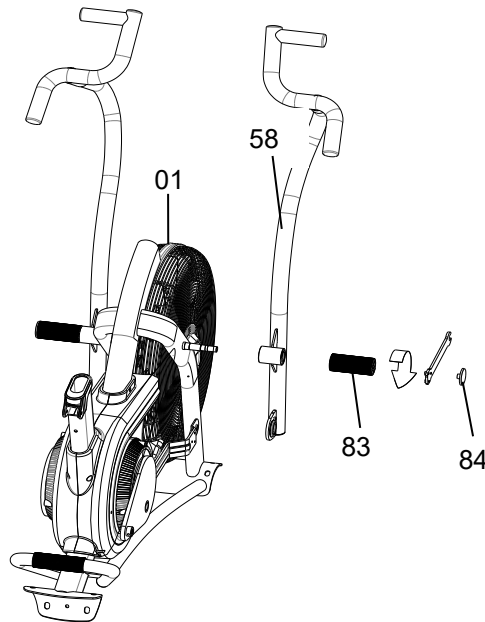

TOOLS:

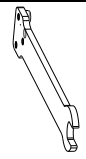

Wrench

3-4. Install the Fix Plate & Linkage Bar

- Connect the **right Dual Action Handlebar (58)** and **Linkage Bar with Fix Plate (74)**, **Disc Spacer (75)**, **M8x30mm Screw (105)** and **M8 Nylon Locknut (93)** and tighten with 5mm Allen Key & 14/17 Wrench.
- Doubly secure the **Fix Plate (74)** to the Linkage Bar with three **M6x15mm Screws (107)** and secure with 4mm Allen Key.

Be sure to fit the parts in the same order as the diagrams shown.

Make sure the screws are fully tightened with the allen key.

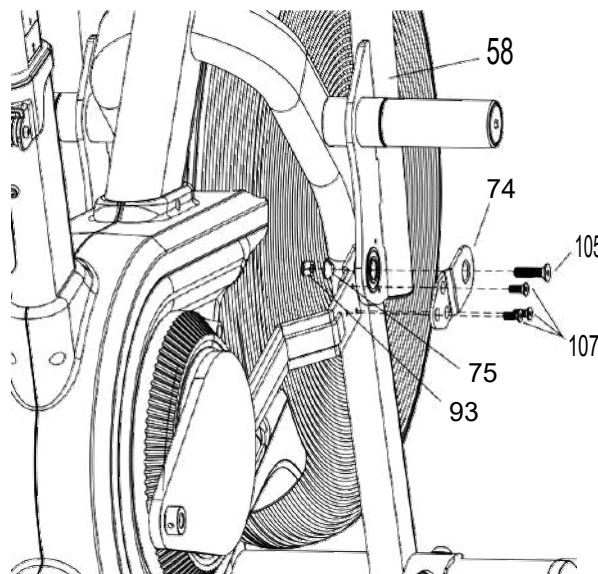

FIXINGS:



x 1



x 1



x 1



x 3

TOOLS:

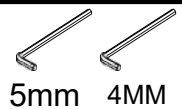

5mm 4MM

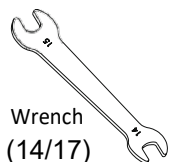

Wrench
(14/17)

4. Attach the Pedals

4-1. Attach the Left Pedal

- Loosen the **Phillip Head Screw (109)** fitted on the left Crank Arm.
- Attach the **Left Pedal (38)** to the left Crank Arm and fasten with the Wrench.
- Fasten the **Phillip Head Screw (109)** to the crank Arm with the 5mm Allen Key.

Be sure to fit the parts in the same order as the diagrams shown.

This pedal will be threaded on clockwise.

Make sure the screw is fully tightened with the allen key.

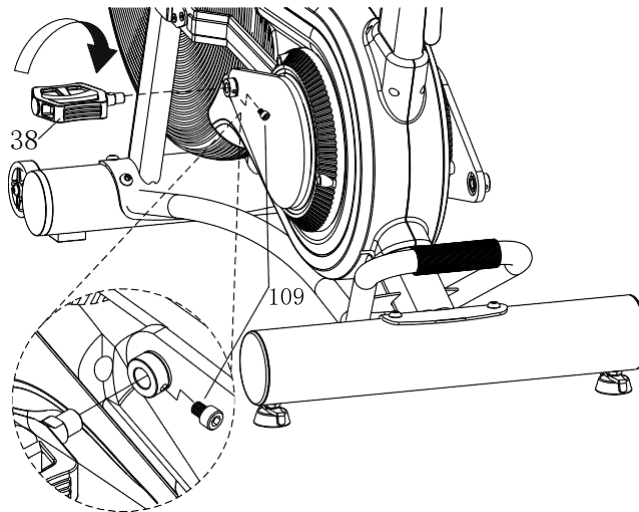

TOOLS:

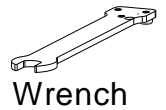
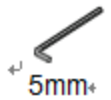

4-2. Attach the Right Pedal

- Loosen the **Phillip Head Screw (109)** fitted on the right Crank Arm.
- Attach the **Right Pedal (39)** to the right Crank Arm and fasten with the Wrench #14 / #15.
- Fasten the **Phillip Head Screw (109)** to the Crank Arm with the 5mm Allen Key.

Be sure to fit the parts in the same order as the diagrams shown.

This pedal will be threaded on clockwise.

Make sure the screw is fully tightened with the allen key.

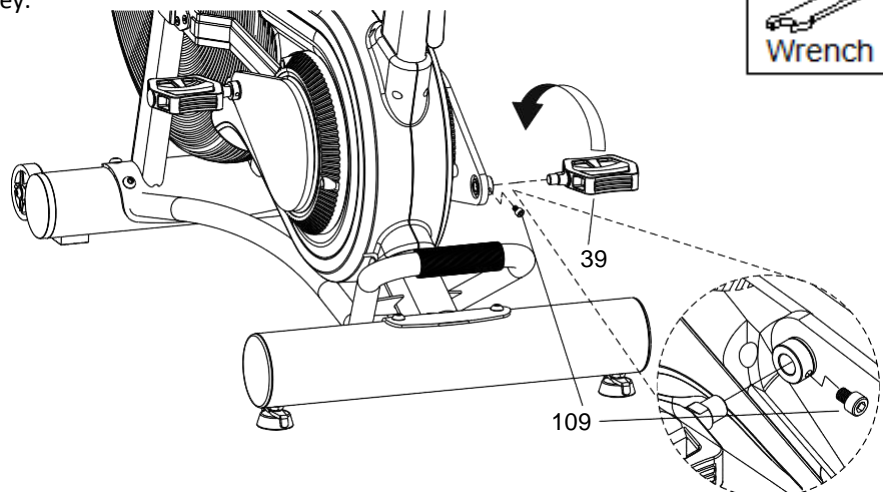

TOOLS:



5. Attach the Console Support

- Connect the **Sensor Cable** and **Middle Wire** together and then attach the **Console Support (48)** to the front end of the **Main Frame (01)** with two **M8x30 mm Screws (105)** and secure with the 5mm Allen Key.

Be sure to fit the parts in the same order as the diagrams shown.

Make sure the cables are fully connected.

Make sure the screws are fully tightened with the allen key.

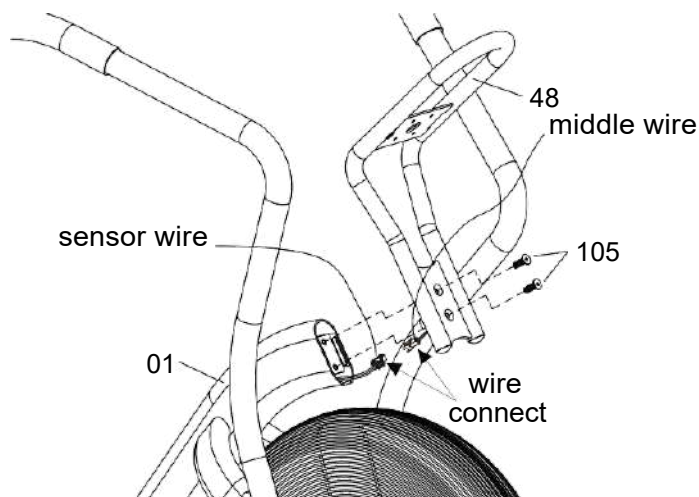

FIXINGS:

Part No.
105



x 2

TOOLS:



5mm

6. Attach the Console

- Remove the four fixing screws which are located in the back of the **Console(85)**.
- Connect the **Console Cable** and **Middle Wire** together and then attach the **Console (85)** to the **Console Support (48)** with four **M5 x 12mm fixing screws(106)** and secure with the Screwdriver.

Be sure to fit the parts in the same order as the diagrams shown.

Make sure the cables are fully connected.

Make sure the screws are fully tightened with the screwdriver.

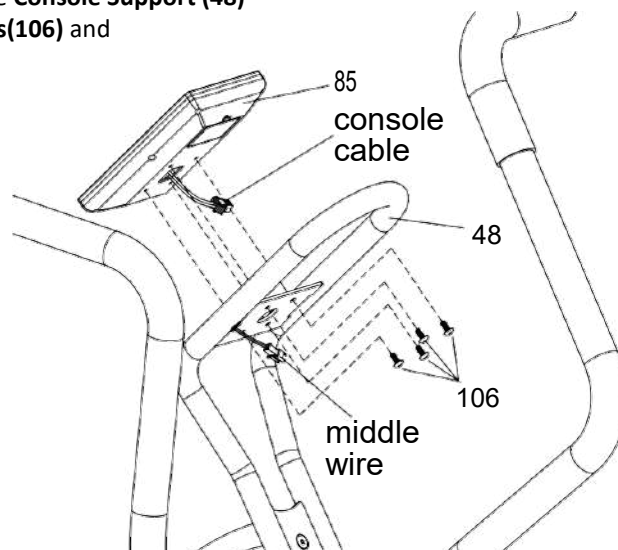

FIXINGS:

Part No.
106



x 4

TOOLS:

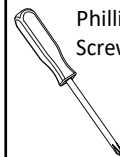

Phillips
Screwdriver

Final Checks

Your cycle is now assembled. Please make the following final checks before you use it for the first time

- Make sure all screws, bolts and nuts are tightened securely
- Make sure you have positioned it on a flat, level surface

Bike Features Explained

Adjusting the seat reach

1. Pull up the **Adjustment Grip (62)** and adjust the reach of the Saddle.
2. Release the **Adjustment Grip (62)** after the proper saddle position had found.

Do not pull the seat post too far - the maximum is indicated on the seat post.

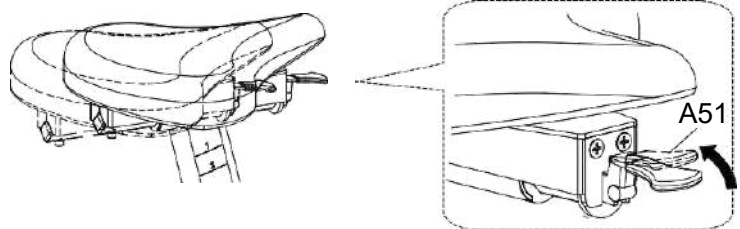

Adjusting the seat height

1. Unlock the **Pop pin spinning Knob (125)** by turning it counterclockwise. Pull the knob and adjust the height of the Seat Post.
2. Let go of the knob and the pin will automatically pop back into the position hole. Tighten the knob by turning it clockwise.

Do not pull the seat post too far - the maximum is indicated on the seat post.

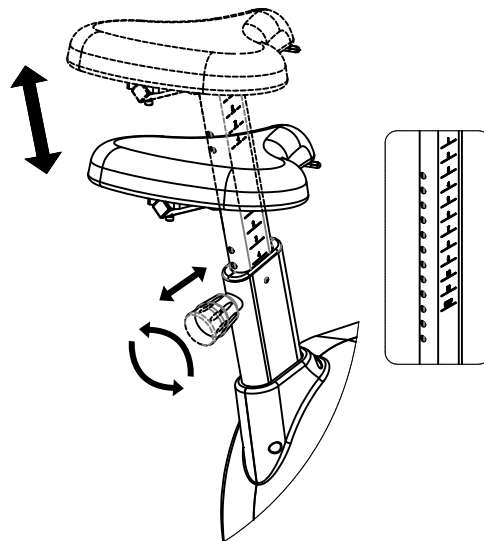

Levelling your air bike

1. To help you level the cycle on uneven surface, 2 height adjusters are included on the rear stabilisers. Simply turn it to adjust the height of the air bike.

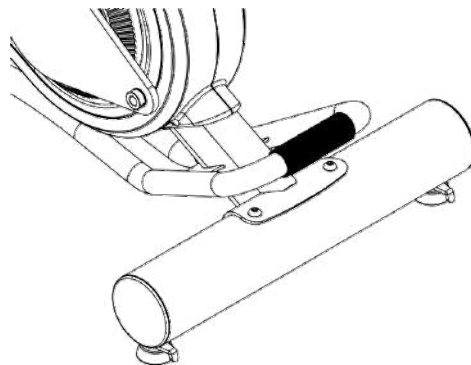

Transporting your air bike

1. Your air bike has 2 transport wheels on the front stabilizer.
2. Lift the bike from the rear end of bike and then pull or push to move it around.

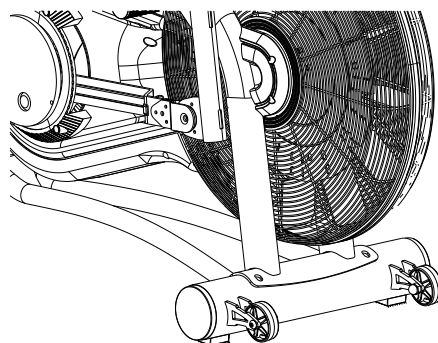

Computer instruction

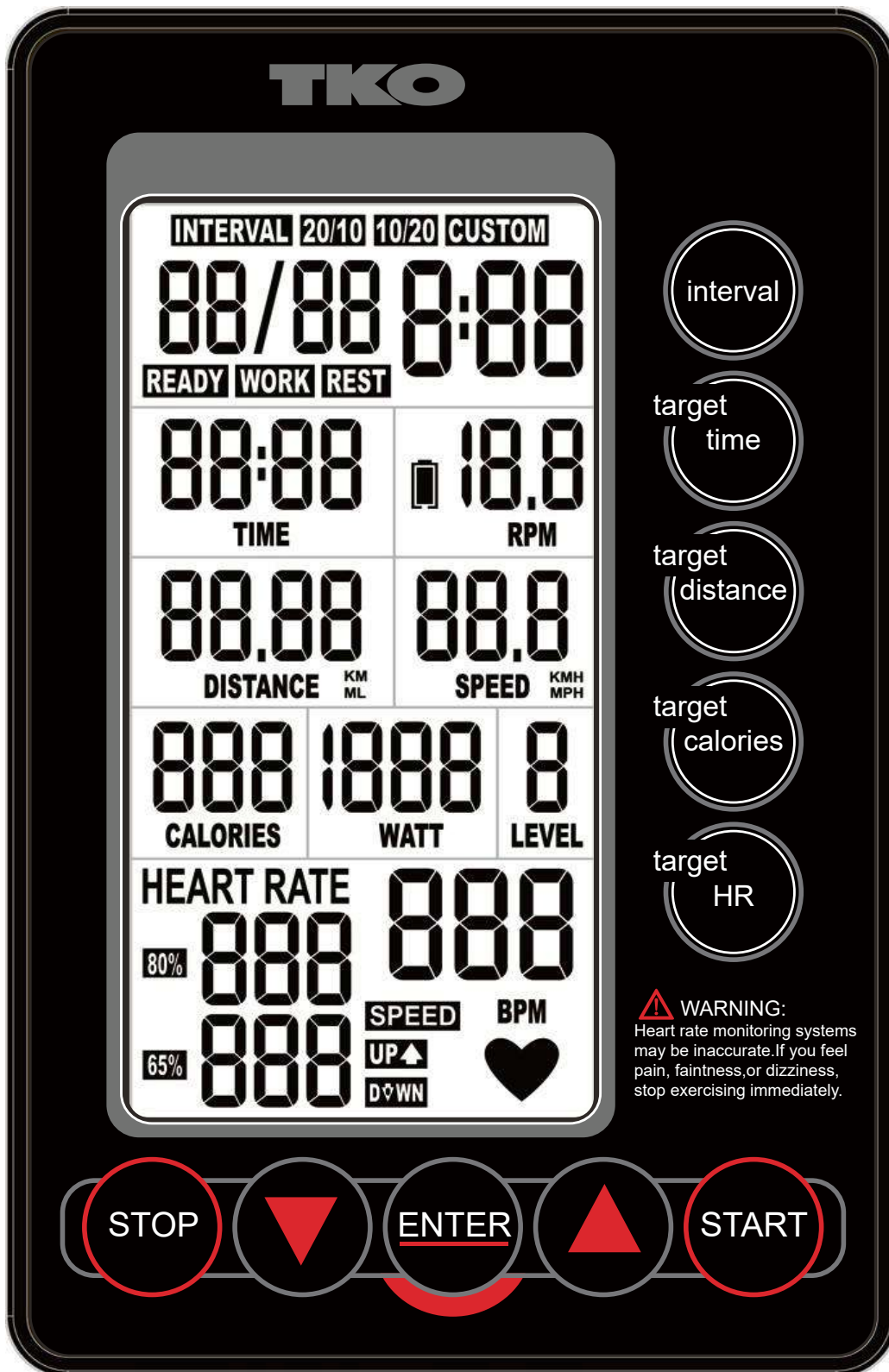

Operating the console:

1. QUICK START OPERATION

Under STAND BY display, the user can enter “QUICK START” mode by pressing the “START” button. And then “TIME, DISTANCE, CALORIES” will ready to count up from zero. After starting the machine, the lever of resistance can be adjusted manually. The system will pause counting TIME/DISTANCE/CALORIES if not receiving RPM signals. The system will continue previous counting once receiving RPM signal. While using, pressing “STOP” button will cease the operation of the console.

2. INTERVAL – PROGRAM

Under STANDBY DISPLAY, pressing “INTERVAL” button one time can enter default setting of interval 20/10 program ; pressing two times continuously can do the setting in Interval 10/20 program ; pressing three times continuously can enter Interval Custom Program to set your own settings.

(A). Setting interval laps on Interval 20/10 Program

Under operating status, when choosing Interval 20/10, Internal 0/10 display will blink, the user can do the setting using “UP/DOWN” button. Press “ENTER” when setting is finished and then press “START” to run the program.

When pressing “START”, the program will operate based on WORK TIME 20 seconds/ REST TIME 10 seconds. Interval takes record on each cycle until reaching the setting laps.

(B). Setting Interval laps on INTERVAL 10/20 program

Under STANDBY mode, when choosing INTERVAL 10/20 program, “ INTERVAL 0/10” display will blink. Use “UP/DOWN” button to do the setting. Press “ENTER” when finishing the setting and then press “START” to start the workout.

When pressing “START”, the program will operate based on WORK TIME 10 seconds/ REST TIME 20 seconds. Interval takes record on each cycle until reaching the setting laps.

(C). Operation on INTERVAL CUSTOM mode

Under STANDBY DISPLAY, when choosing “INTERVAL CUSTOM”, “WORK TIME” will blink.

(1). Setting “WORK TIME”

Use “UP/DOWN” button to set the time on “WORK TIME”. Press “ENTER” when finish the setting, and the program will switch to display on the next setting column.

(2). Setting “REST TIME”

Use “UP/DOWN” button to set the REST TIME. Press “ENTER” when finish the setting, and the program will switch to display on the next setting column.

(3). Setting on INTERVAL laps

Use “UP/DOWN” button to set the INTEVAL laps. Press “ENTER” when the setting is finished. Press “START” to begin the workout.

When pressing “START”, the program will operate based on WORK TIME/ TEST TIME the user has set. Interval takes record on each cycle until reaching the setting laps.

3. TARGET TIME – PROGRAM

Under STANDBY DISPLAY, pressing “TIME” program will enter the operation of this program.

(1). Setting TIME

When choosing TIME PROGRAM and pressing “ENTER”, the program switch to the default time of 30 seconds in blinking display.

Press “UP/DOWN” button to set TIME or not changing the default time, press “ENTER” to save the setting.

(2). The processing mode after “START”

- a. Under processing mode, TIME counts in decrement, DISTANCE/CALORIES counts in increment.
- b. Console will stop function when pressing “STOP” during operation.

4. TARGET DISTANCE – PROGRAM

Under STANDBY DISPLAY, press “DISTANCE” program to enter the setting of this program.

(1). Setting DISTANCE

When choosing DISTANCE PROGRAM and pressing “ENTER”, the program switches to the default setting of 5.00 and display in blink.

Press “UP/DOWN” button to set DISTANCE or not changing the default distance. Press “ENTER” to save the setting.

(2). The processing mode after “START”

- a. Under processing mode, DISTANCE display counts in decrement, TIME/CALORIES counts in increment.
- b. Console will stop function when pressing “STOP” during operation.

5. TARGET CALORIES – PROGRAM

Under STANDBY DISPLAY, pressing “CALORIES” program to enter the setting of this program.

(1). Setting CALORIES

When choosing CALORIES PROGRAM and pressing “ENTER”, the program switches to the default setting of 50 calories and display in blink.

Press “UP/DOWN” button to set CALORIES or not changing the default calories. Press “ENTER” to save the setting.

(2). The processing mode after “START”

- a. Under processing mode, CALORIES display counts in decrement, TIME/DISTANCE counts in increment.
- b. Console will stop function when pressing “STOP” during operation.

6. TARGET HR PROGRAM

Under STANDBY DISPLAY, press “HR” program to enter the setting of this program.

(1). Setting AGE

When pressing HR program, console displays initial age setting of 30 years old. Press “UP/DOWN” button to setting age, and press “ENTER” to save the setting. Press “START” to begin the workout.

(2). The processing mode after “START”

- a. Under processing mode, TIME/DISTANCE/CALORIES display counts in increment.
- b. Console will stop function when pressing “STOP” during operation.

How to Take Care of Your Cycle

Storage

Keep the equipment in a dry place with as little temperature variation as possible. Try to protect from dust and always unplug when not in use (if applicable).

Cleaning

Use a warm, damp cloth to wipe the surfaces. Mild detergent may be used if necessary.

Never remove the protective casing.

Maintenance

Ensure you regularly check components for wear and make sure all the nuts and bolts are tightened before each exercise session.

Troubleshooting

If you have a problem with your equipment, before you do anything else please check that all the cables have been connected correctly. Loose cables are very common and many problems can be solved by making sure the cables are properly connected

If you are having problems with your heart rate reading please note that some fibres used in clothes eg) polyester, create static electricity that may prevent a reliable heart rate reading. Mobile phones, TV's, microwaves and other electrical appliances that generate an electromagnetic field may also interfere with heart rate measurement.

If you are still having problems with your equipment, please get in touch with your local distributor using the details found in the Customer Support section on page 5.

Exercising with Your Cycle

Always consult your doctor before undertaking a new exercise regime

If you experience nausea, dizziness or other abnormal symptoms during exercise, stop at once and consult your doctor

Starting and finishing your workout

Begin and end each workout with a Warm Up / Down session – a few minutes of stretching to help prevent strains, pulls and cramps

Correct cycling form

- Sit on the cycle, with your feet on the pedals and inside the pedal straps
- Ensure that the seat height is adjusted correctly - you should be stable and balanced whilst on the saddle. The basic rule for getting the seat height right is that as the pedal reaches its lowest point, the leg is almost straight.
- Try to ensure that your back is straight whilst exercising, especially for long periods.

How long should I exercise for?

That really depends on your current level of fitness. If you're just starting out on a new exercise program, you should start gradually and build up – do not try to do too much too quickly. 30 minutes,

3 times a week should be enough.

Don't push yourself too hard - you should never feel exhausted during or following exercise.

Heart Rate Training

To get the most out of your new piece of fitness equipment and see the best results from your training you should exercise at the right level of effort, and that means listening to your heart! Working out to a target heart rate means you can direct your workout to achieve different goals:

Good health - For those wishing to improve quality of life and general well being. Your sessions will need to be done at an intensity of between 50-60% of your estimated maximum heart rate, should last about 30 minutes and can be done on most days of the week.

Weight loss – To see a significant reduction in body fat, your sessions must be a little more intense - between 60 and 70% of your estimated maximum heart rate. These sessions can also be performed on most days of the week for up to 30 minutes.

Improving Fitness levels – These sessions should be performed at 70-80% of your estimated maximum heart rate and can also involve bouts of interval training that would have your heart rate peaking for short times near your maximum heart rate level. These are intense sessions and will require at least a 48 hour rest between sessions.

Calculating your target heart rate

First, you need to find your estimated maximum heart rate using the formula '220 minus your age in years'. So, if you are 35 years old your estimated maximum heart rate is:

$$220 - 35 = 185 \text{ beats per minute (bpm)}$$

Next, to calculate your target heart rate, simply multiply your estimated maximum heart rate (185bpm) by the applicable percentage. So, if your goal is better health:

$$185 \times 60\% = 111\text{bpm}$$

NOTE: The important issue to remember with all estimated calculations is that they are just estimates – if you don't feel comfortable exercising at your target then reduce it to a level you are comfortable with.

Note: Heart rate training requires you to monitor your heart rate throughout the workout. For this we recommend using a chest strap (if your machine has a wireless receiver) or a heart rate monitor.

Explored Diagram

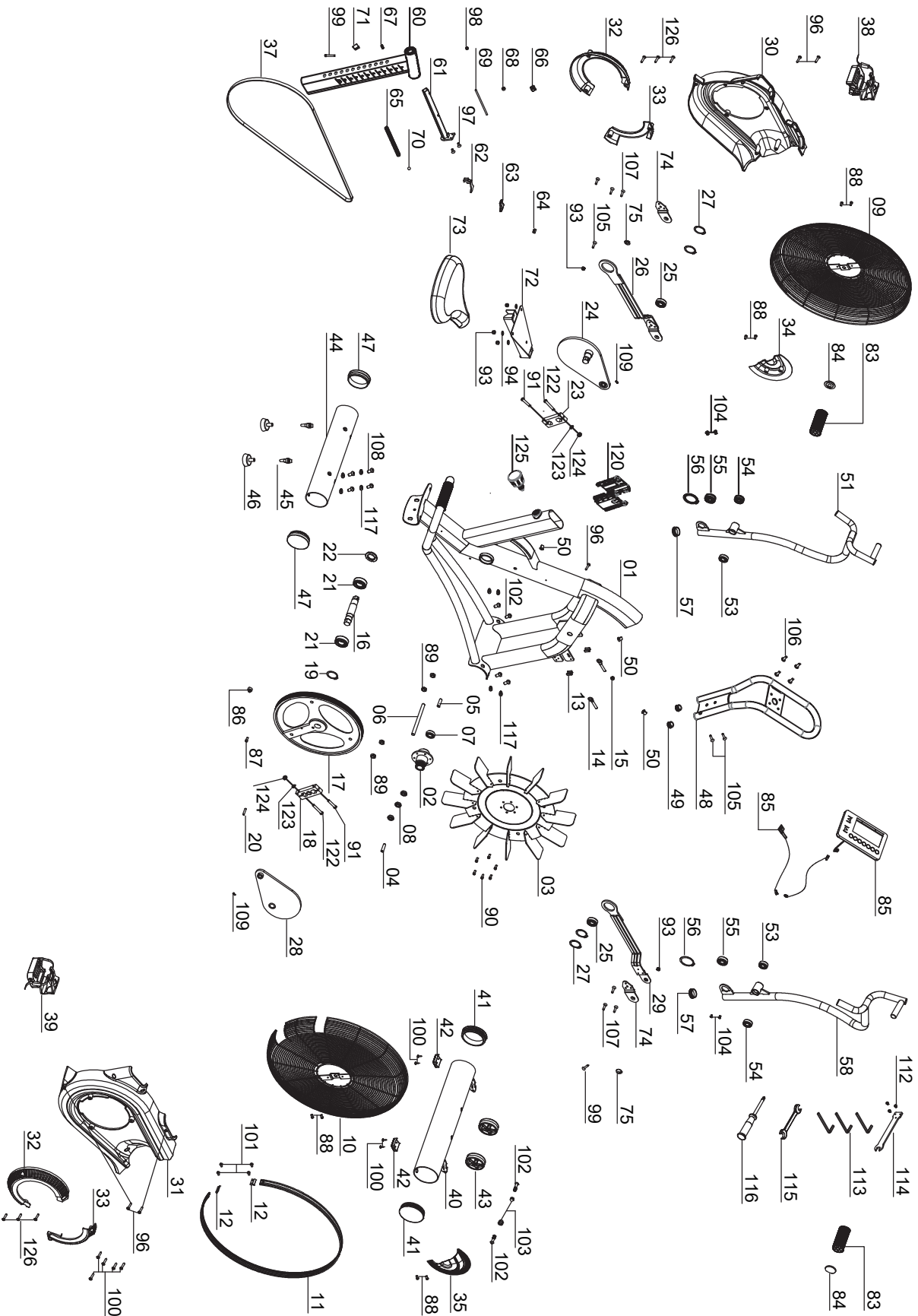

Parts List

NO	Name of the product	Q'TY	NO	Name of the product	Q'TY
01	Main Frame	1	46	Foot pad	2
02	Fan wheel hub set	1	47	Rear foot pipe plug	1
03	Fan wheel	1	48	Console support	1
04	Fan wheel hub sleeve	1	49	Circular tube plug	2
05	Fan wheel hub sleeve	1	50	Wire plug	2
06	Fan hub	1	51	Left dual action handlebar	1
07	Bearing 6301Z	1	52	Dipping plastic	1
08	Bearing 6901Z	3	53	Bearing 6003Z	2
09	Left protection network group	1	54	Bearing 6202Z	2
10	Right protection network group	1	55	Bearing 6203Z	2
11	Protection network hoops	1	56	C-type buckle	2
12	Protective net compression sheet	2	57	Pipe inside plug	2
13	Baffle	2	58	Right dual action handlebar	1
14	Cat eye screw M8*45	2	60	Seat cushion up and down adjustment group	1
15	Cap M8	2	61	Seat cushion front and rear adjustment group	1
16	Crankshaft center	1	62	Socket wrench welding part	1
17	Pulley	1	63	Adjustable wrench with plastic sheath	1
18	Right-square crank	1	64	Seat cushion adjustable short shaft	1
19	C-type buckle	1	65	Seat cushion adjustable long pressure spring	1
20	Elastic cylindrical pin	1	66	Set piece	1
21	Bearing 6005	2	67	Seat cushion adjustable short pressure spring	1
22	Crankshaft center lock nut	1	68	Seat cushion adjustable small sleeve	1
23	Left - square crank	1	69	Seat cushion adjustable long shaft	1
24	Left – disc crank group	1	70	Seat adjustable positioning steel ball	1
25	Bearing 22052RS/NR	2	71	Pipe plug	1
26	Left - swing arm link	1	72	Seat cushion holder	1
27	C-type buckle	4	73	Seat cushion	1
28	Right-disc crank group	1	74	Front outboard piece	1
29	Right-swing arm link	1	75	Conical sleeve	2
30	Left protection cover	1	83	Aluminium alloy pedal	2
31	Right protection cover	1	84	Decorative plug	2
32	Crank guard-down	1	85	Console	1
33	Crank guard-on	1	86	Induced magnet	1
34	Left-front decorative cover	1	87	Cylindrical head socket screw M8*20	1
35	Right-front decorative cover	1	88	Cylindrical head socket screw M5*12	8
37	Belt	1	89	Hex nut M12*1.25	4
38	Left pedal	1			
39	Right pedal	1			
40	Forefoot tube group	1			
41	Round plug	2			
42	Square foot pad	2			
43	Moving wheels	2			
44	Rear foot tube group	1			
45	Adjustment board	1			

No.	Name of the product	QTY	No.	Name of the product	QTY
90	Cylindrical head socket screw M6*12	6	112	Cylindrical head socket screw M5*6	3
91	Cylindrical head socket screw M10*40	2	113	Allen key 4MM/5MM/6MM	1+1+1
93	Cap M8	5	114	Wrench(14/17)	1
94	Flat washer	3	115	Wrench	1
96	Pan head cross self tapping screw ST4*10	7	116	Phillips screwdriver	1
97	Countersunk head cross screw M6*15	2	117	Arc washer	8
98	Cap M6	1	120	Seat hollow plug	2
99	Cylindrical head socket screw M6*35	1	122	Socket head cap screw M10x50mm	2
100	Phillips pan head self-tapping screw (ST4 x 15mm)	9	123	Spring washer M10	2
101	Countersunk head cross screw M4*10	4	124	Hex nut M10	2
102	Umbrella head socket screw M8*50	2	125	Pop pin spinning knob	1
103	Cap screw M8	3	126	Phillips pan head self-tapping screw ST4x45	6
104	Pan head cross screw M5*8	4			
105	Countersunk head socket screw M8*30	4			
106	Pan head cross screw M5*12	4			
107	Countersunk head socket screw M6*15	6			
108	Umbrella head socket screw M10*20	8			
109	Cylindrical head socket screw M6*10	2			