

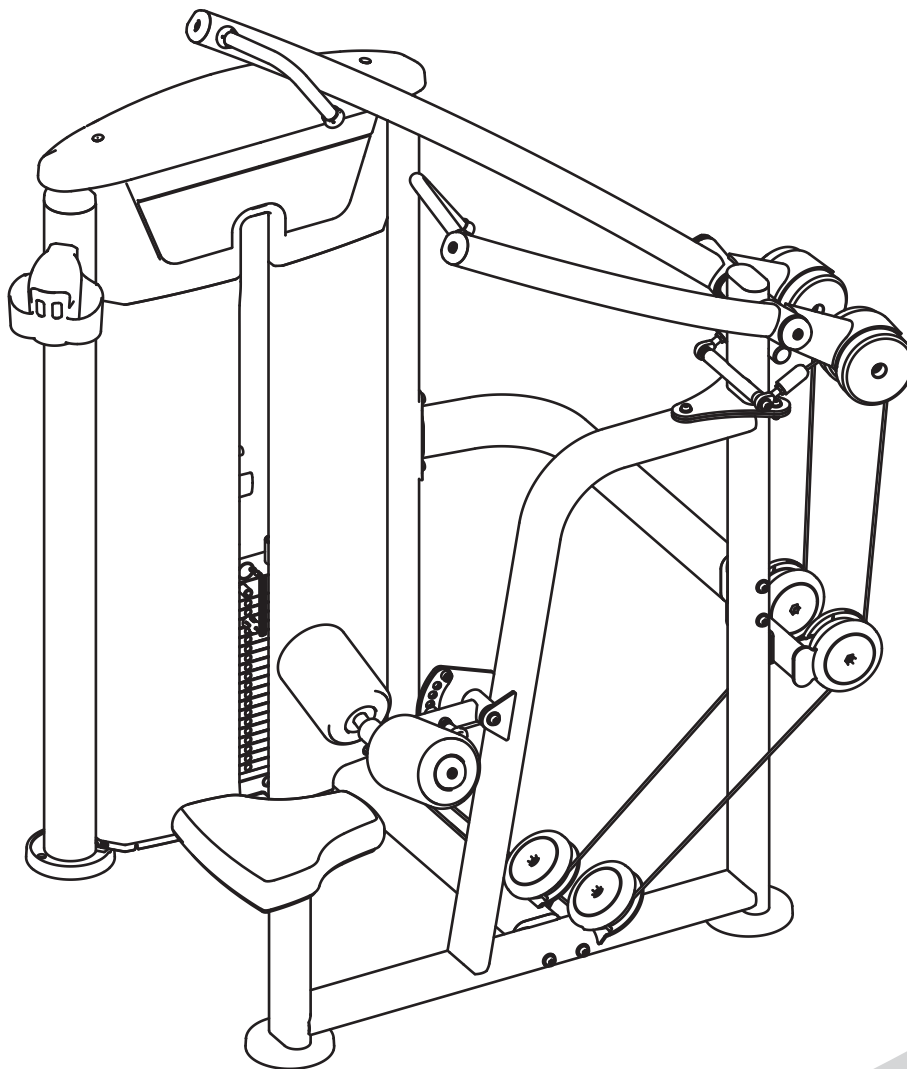

# 7006-G2

LAT PULL

## Owner's Manual



### **! CAUTION**

Read all precautions  
and instructions in this manual  
before using this equipment

# Table Of Contents

## CAUTION!

Read all precautions and instructions in this manual before using this equipment.

Important Safety Instructions-----	3
Instructions-----	5
Exploded View and Parts List-----	6
Measurement Guide-----	18
Assembly Instructions-----	19
Assembly-----	20
Adjust Instructions-----	31
Exercise Instructions-----	32
Maintenance Schedule-----	33
General Maintenance Information-----	34
Weight Training Tips-----	35

Please assemble according to the actual **Weights** you buy !

---

# Important Safety Instructions

Before beginning any fitness program, you should obtain a complete physical examination from your physician. When using exercise equipment, basic precautions should always be taken, including the following:

1. Read all instructions before using the equipment.  
These instructions are written to ensure your safety and to protect the unit.
2. Use the equipment only for its intended purpose as described in this guide.  
Do not use accessory attachments that are not recommended by the manufacturer: such attachments might cause injuries.
3. The product should only be used on a level surface and is with 0.5 meters space around the product.  
Do not use the equipment outdoors.
4. Do not allow children on or near the equipment. And children are not allowed to use this equipment.  
Teenagers should use this equipment with adult supervision.
5. Do not overexert yourself or work to exhaustion.  
Do not attempt to lift more weight than you can control safely.  
If you feel any pain or abnormal symptoms, stop your workout immediately and consult your physician.
6. This equipment is not used as medical apparatus and instruments.
7. Never operate the unit when it has been dropped or damaged.  
Never drop or insert anything into any opening in the equipment.  
Always check the unit and its cables before each use. Make sure that all fasteners and cables are secure and in good working condition.  
Frayed or worn cables can be dangerous and may cause injury. Periodically check these cables for any indication of wear.  
Keep hands, limbs, loose clothing and long hair well out of the way of moving parts.
8. Be careful when getting on or off the equipment.
9. Wear proper exercise clothing and shoes for your workout, no loose clothing.

# Important Safety Instructions

## Personal Safety During Assembly

Read each step in the assembly instructions and follow the steps in sequence. Do not skip ahead. If you skip ahead, you may learn later that you have to disassemble components and that you may have damaged the equipment.

Assemble and operate the equipment on a solid, level surface. Locate the unit a few feet from walls or furniture to provide easy access. The equipment is designed for your enjoyment. By following these precautions and using common sense, you will have many safe and pleasurable hours of healthful exercise with the equipment.

## Training Area and Free Area

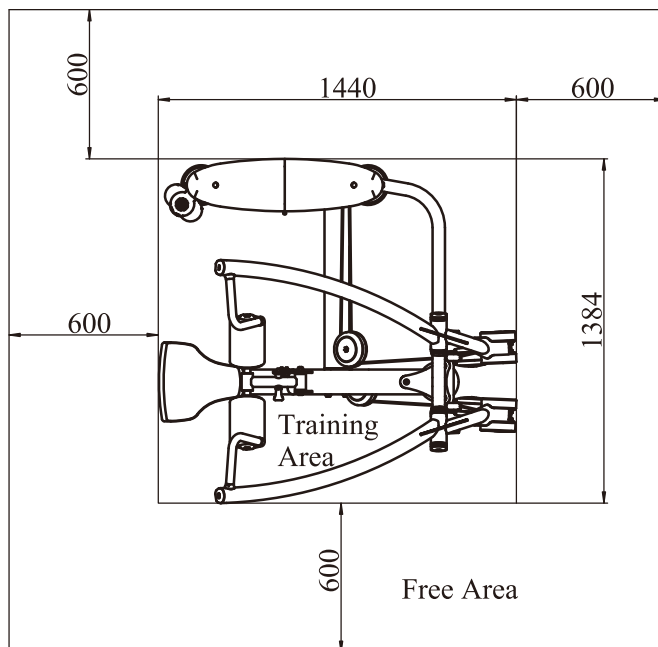

## Specifications

Class: S

Maximum Wt. Capacity: 134kg/ 295lbs

Maximum User Weight: 150kg/ 330lbs

Product Total Surface: 1440\*1384mm

Product Total Mass: 147.7kg/ 326lbs

# Instructions

Before beginning assembly please take the time to read instructions thoroughly. Please use the various lists in this manual to make sure that all parts have been included in your shipment. When ordering, use part number and description from the lists. Use only our replacement part when servicing. Failure to do so will void your warranty and could result in personal injury.

The equipment is designed to provide the smoothest, most effective exercise motion possible. After assembly, you should check all functions to ensure correct operation. If you experience problems, first recheck the assembly instructions to locate any possible errors made during assembly. If you are unable to correct the problem, call your authorized dealer. Be sure to have your serial number and this manual when calling. When all parts have been accounted for, continue on.

## Tools Required

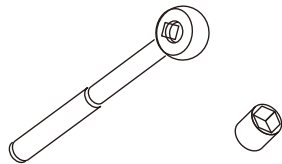

Ratchet Wrench and Socket

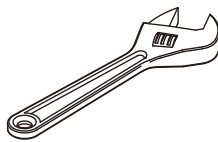

Adjustable Wrench

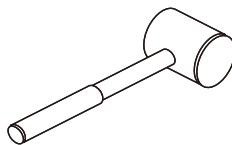

Rubber Mallet

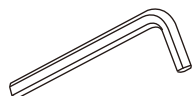

Hex Key Wrench Set

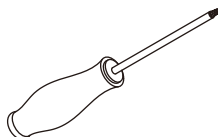

Phillips Screwdriver

# Exploded View and Parts List

## Overall

Item No.	Grade No.	Part No.	Description	QTY
1	1	IT950101ASSY	Weight Stack Frame ASSY	1
2	2	IT950201ASSY	Front Frame ASSY	1
3	3	IT950202V1ASSY	Top Connection Frame ASSY	1
4	4	IT950203V1ASSY	Right Arm Frame ASSY	1
5	5	IT950204V1ASSY	Left Arm Frame ASSY	1
6	6	IT950205ASSY	Bottom Cross Brace ASSY	1
7	7	IT950206ASSY	FOAM Frame ASSY	1
8	8	IT95050300	Rear Connection Frame	1
9	9	IT95020700	DIP Cable	1
10	10	IT95120800	Tension Cable ASSY	1
11	11	PL90101200	V-type Pulley	2
12	12	SD1000B3000ASSY	Adjustable Foot Plate	2
13	21	IT950121ASSY	Top Bracket ASSY	1
14	22	IT950122ASSY	Bottom Bracket ASSY	2
15	23	IT95012300	Rear Bracket	1
16	24	IT95012400	Double Pulley Bracket	1
17	25	IT95016000	Plastic Cover	2
18	26	IT95016400	Pulley Cover	4
20	28	SG500110400V5	4.5" Pulley	7
21	31	IE950221ASSY	Shot FOAM ASSY	2
22	42	IT95014200	Top Plate	1
23	44	IT95014400	Guide Rod $\Phi$ 19*1242	2
24	51	IT95015100	Top Cover	1
25	52	IT95015200	Training Placard Cover	1
26	53	IT95015300	Front Shroud	1
27	54	IT95015400	Right Front Shroud	1
28	55	IT95015500	Top Rear Shroud	1
29	56	IT95015600	Rear Shroud	1
30	76	IT95017600	Seat Pad	1
31	92	IT801210300P11C	Cup Holder	1
32	101	FE970113100	Cable Connector Jacket	2

# Exploded View and Parts List

## Overall

Item No.	Grade No.	Part No.	Description	QTY
33	102	FE970113200	Cable Connector	2
34	103	FE97211900	Cap $\Phi$ 60	4
35	104	FE97212000	Circle Ring $\Phi$ 62.5*5	4
36	105	IT80023000	Weight Rubber Bumper	2
37	106	IT90012000V1	Selector Pin W/Coil	1
38	107	FE97193400	Pulley Spacer	1
39	108	IT95016100	Guide Rod Fixing Sleeve $\Phi$ 25* $\Phi$ 19*45	2
40	109	IT95016500	Spout Plug $\Phi$ 16.5*6.88	2
41	110	HFOPT900-04A0602	Spring	2
42	111	GB70BTM12*135DN18	Socket Head Cap Screw M12*135	4
43	112	GB70BTM12*105DN18	Socket Head Cap Screw M12*30	1
44	113	GB70BTM12*30DN18	Socket Head Cap Screw M10*80	2
45	114	GB70BTM10*80DN18	Socket Head Cap Screw M10*80	3
46	115	GB70BTM10*75DN18	Socket Head Cap Screw M10*80	4
47	116	GB70BTM10*70DN18	Socket Head Cap Screw M10*80	2
48	117	GB70BTM10*50DN18	Socket Head Cap Screw M10*80	4
49	118	GB70BTM10*30DN18	Socket Head Cap Screw M10*80	4
50	119	GB70BTM10*25DN18	Socket Head Cap Screw M10*80	4
51	120	GB70M8*20N19	Socket Head Cap Screw M8*20	2
52	121	GB818M6*20DHS2	Cross Recessed Pan Head Screw M6*16	18
53	122	GB818M6*16DHS2	Cross Recessed Pan Head Screw M6*16	4
54	123	GB818M6*10DHS2	Cross Recessed Pan Head Screw M6*16	4
55	124	GB9512DN2	Flat Washer $\Phi$ 13* $\Phi$ 24*2.5	8
56	125	GB9510DN2	Flat Washer $\Phi$ 11* $\Phi$ 20*2	28
57	126	GB958DN2	Flat Washer $\Phi$ 9* $\Phi$ 16*1.6	2
58	127	NM12DN2	Nylon Lock Nut M12	1
59	128	NM10DN2	Nylon Lock Nut M10	15
60	129	NBS6DHS	Hex Key S=6	1
61	130	NBS8DHS	Hex Key S=8	1
62	131	LW200BS	Wrench $\Phi$ 6*117	1
63	132	YHY	Lube	1
64	133	IT80124103	Split Pin $\Phi$ 11*76	1

# Exploded View and Parts List

Overall

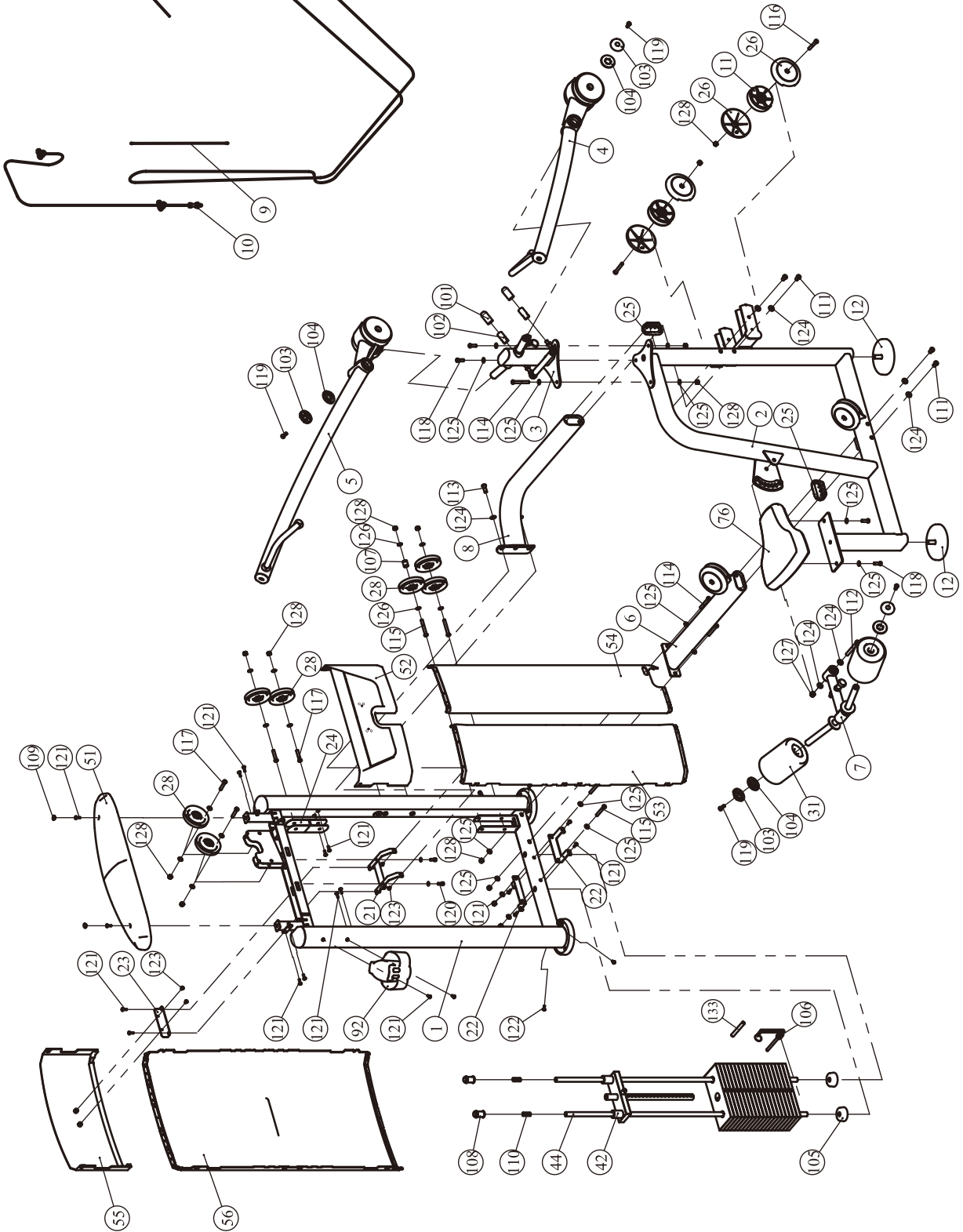



# Exploded View and Parts List

## Weight Stack Frame ASSY

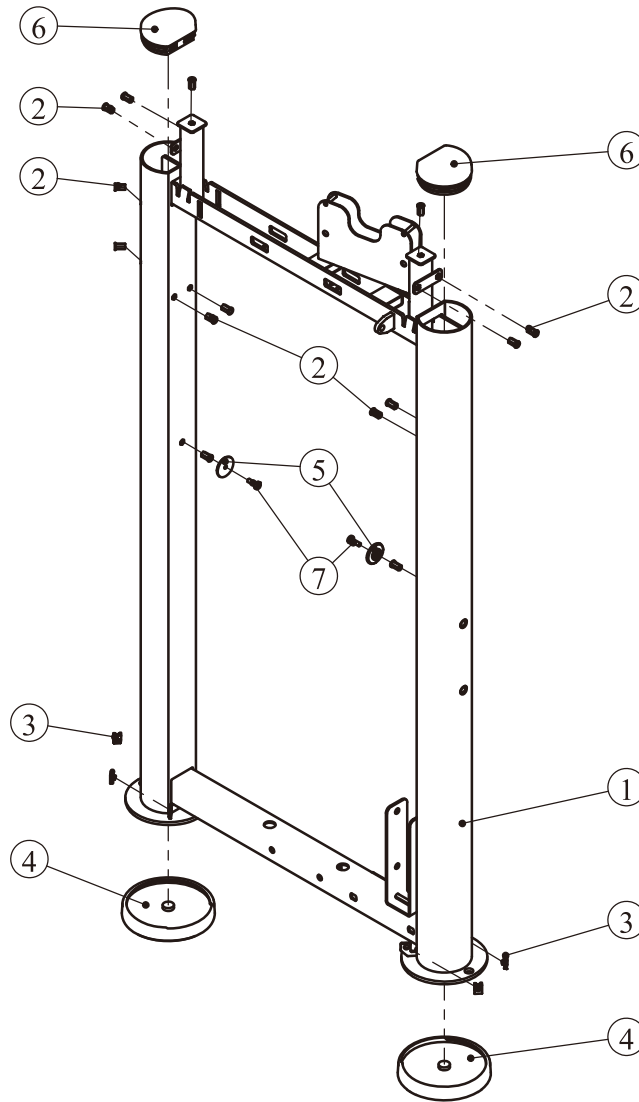

ItemNo.	Grade No.	Part No.	Description	QTY
1	1.1	IT95010100	Weight Stack Frame	1
2	1.2	GB17880.5M6*16.5DS17	Rivet Nut M6	14
3	1.3	AC32705800	U-nut M6	4
4	1.4	IT95015700	Foot Plate	2
5	1.5	IT95015900	Plastic Block	2
6	1.6	IT95015800	Plug $\Phi 95*81.1$	2
7	1.7	GB818M6*20DHS2	Cross Recessed Pan Head Screw M6*20	2

# Exploded View and Parts List

## Front Frame ASSY

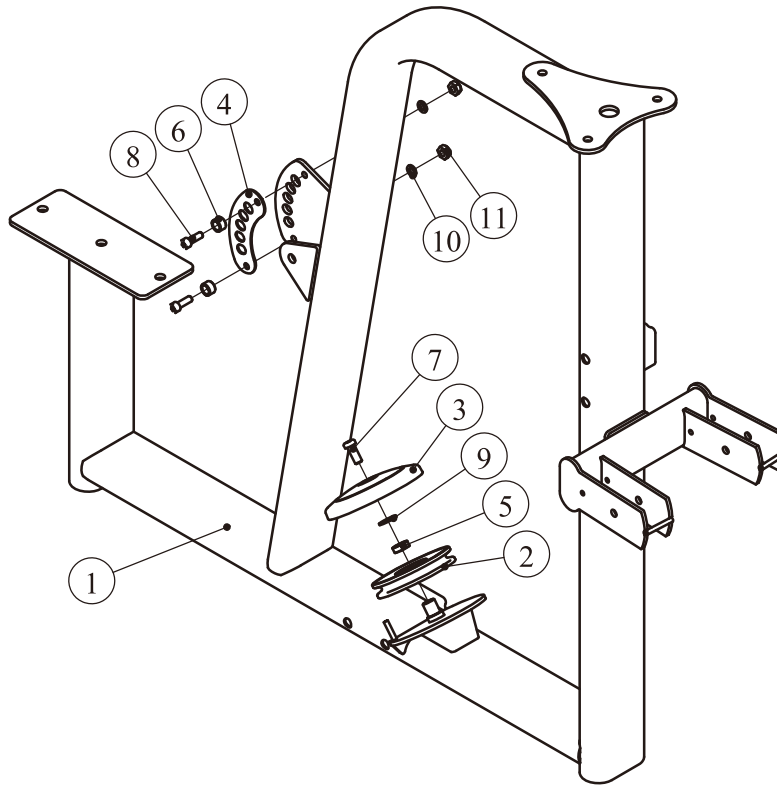

ItemNo.	Grade No.	Part No.	Description	QTY
1	2.1	IT95020100	Front Frame	1
2	2.2	IT95057800	4.5" Pulley	1
3	2.3	IT95016400	Pulley Cover	1
4	2.4	IT90021100	Lining Board	1
5	2.5	FE97122100	Pulley Spacer 1	1
6	2.6	IN-S10111200	Rubber Sleeve $\Phi 17*10.5$	2
7	2.7	GB70BTM10*25DN18	Socket Head Cap Screw M10*25	1
8	2.8	GB70M8*20DS20	Socket Head Cap Screw M8*20	2
9	2.9	DQ10N19B	Flat Washer $\Phi 11*\Phi 25*2$	1
10	2.10	GB958DN2	Flat Washer $\Phi 9*\Phi 16*1.6$	2
11	2.11	NM8DN2	Nylon Lock Nut M8	2

# Exploded View and Parts List

## Top Connection Frame ASSY

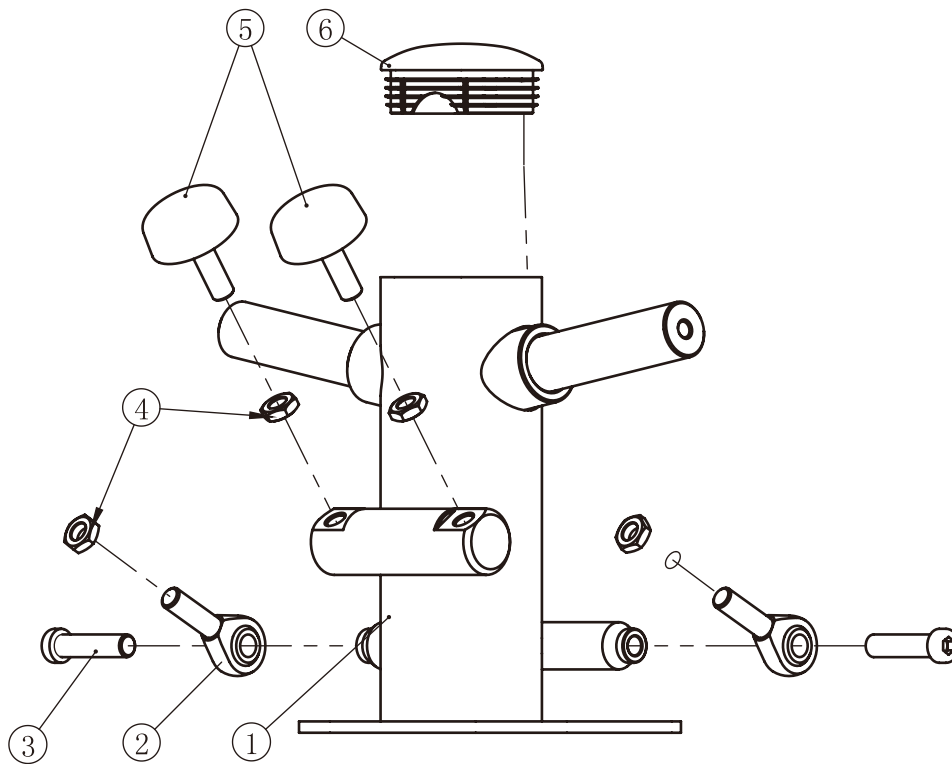

ItemNo.	Grade No.	Part No.	Description	QTY
1	3.1	IT95020200V1	Top Connection Frame	1
2	3.2	SA12T_K	Joint Bearing M12	2
3	3.3	GB70BTM12*35DN18NL	Socket Head Cap Screw M12*35	2
4	3.4	GB6172.1M12DN2	Hexagon Thin Nut M12	4
5	3.5	IT95122200	Urethane Bunper	2
6	3.6	IT90013800P11C	Plug RT50*100	1

# Exploded View and Parts List

## Right Arm Frame ASSY

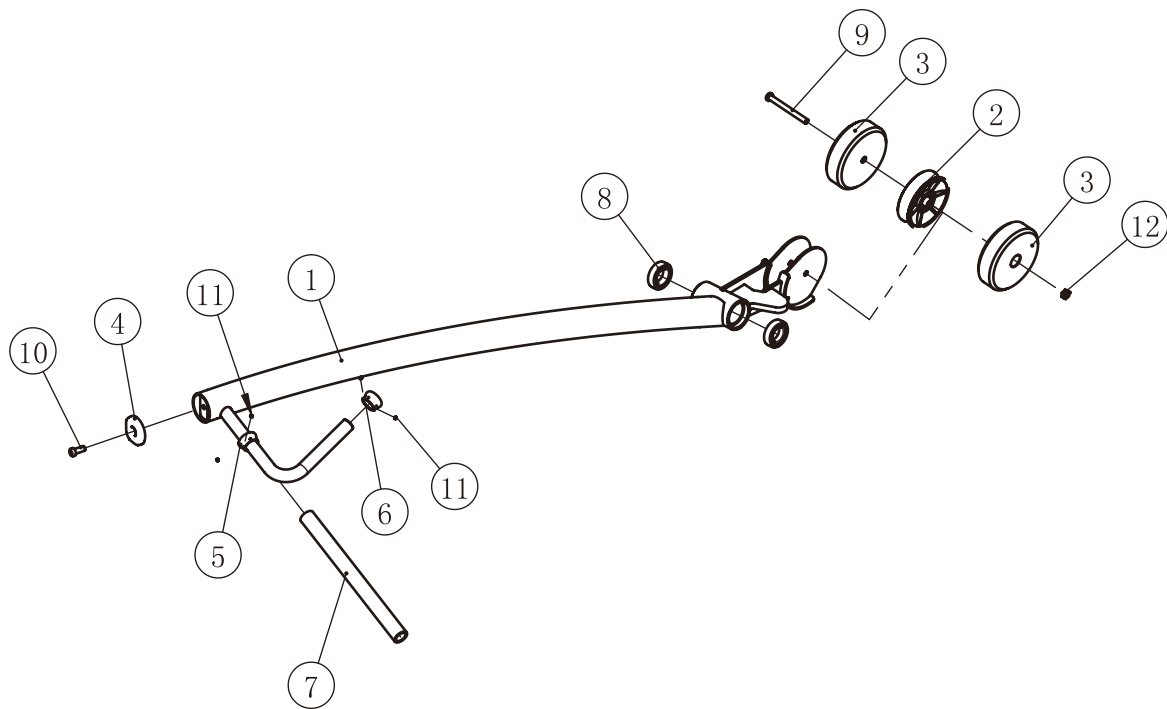

Item No.	Grade No.	Part No.	Description	QTY
1	4.1	IT95020300V1	Right Arm Frame	1
2	4.2	PL90101200	V-type Pulley	1
3	4.3	IT95021100	Poise Block	2
4	4.4	FE97211900	Cap $\phi$ 60	1
5	4.5	IT90102200	Aluminum Grip Ring	1
6	4.6	IT95022100	Aluminum Grip Cap	1
7	4.7	IT95032100	Grip	1
8	4.8	GB2766006-2RSC3NBK	Deep Groove Ball Bearing $\phi$ 25* $\phi$ 52*15	2
9	4.9	GB70BTM10*100DN18	Socket Head Cap Screw M10*100	1
10	4.10	GB70BTM10*25DN18	Socket Head Cap Screw M10*25	1
11	4.11	YZGB7710-32*3.2N19	Socket Set Screw 10-32UNF*3.2	4
12	4.12	NM10DN2	Nylon Lock Nut M10	1

# Exploded View and Parts List

## Left Arm Brace ASSY

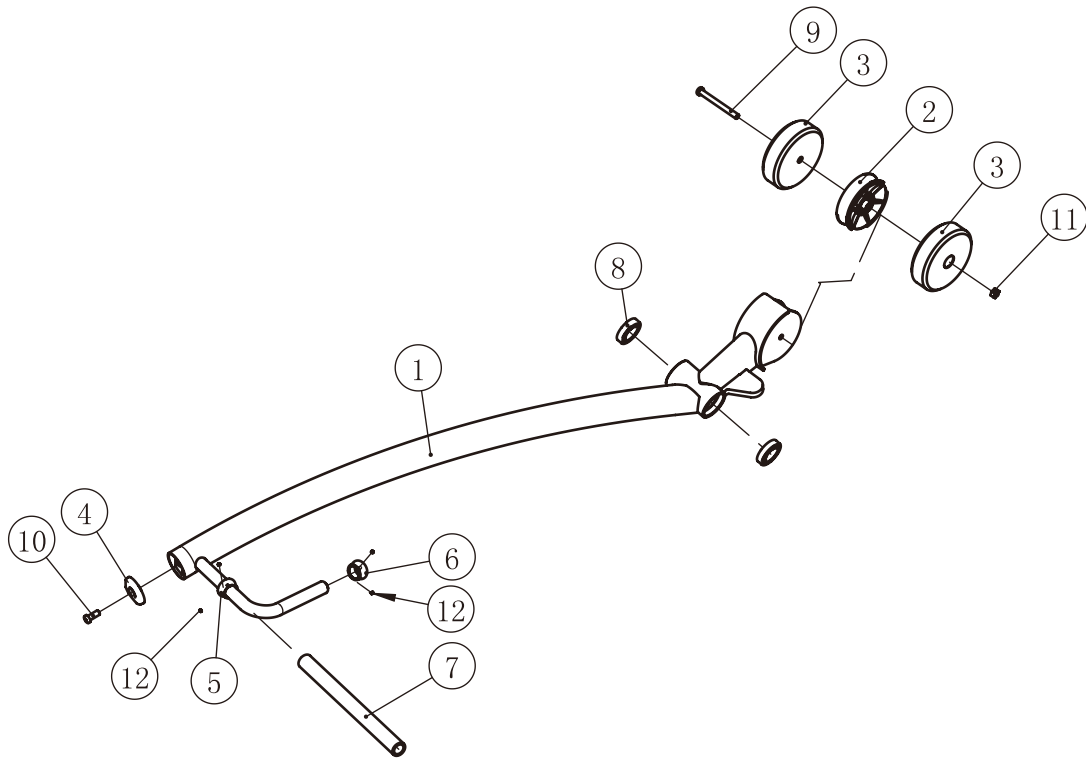

Item No.	Grade No.	Part No.	Description	QTY
1	5.1	IT95020400V1	Left Arm Frame	1
2	5.2	PL90101200	V-type Pulley	1
3	5.3	IT95021100	Poise Block	2
4	5.4	FE97211900	Cap $\phi$ 60	1
5	5.5	IT90102200	Aluminum Grip Ring	1
6	5.6	IT95022100	Aluminum Grip Cap	1
7	5.7	IT95032100	Grip	1
8	5.8	GB2766006-2RSC3NBK	Deep Groove Ball Bearing $\phi$ 25* $\phi$ 52*15	2
9	5.9	GB70BTM10*100DN18	Socket Head Cap Screw M10*100	1
10	5.10	GB70BTM10*25DN18	Socket Head Cap Screw M10*25	1
11	5.11	NM10DN2	Nylon Lock Nut M10	1
12	5.12	YZGB7710-32*3.2N19	Socket Set Screw 10-32UNF*3.2	4

# Exploded View and Parts List

## Bottom Cross Brace ASSY

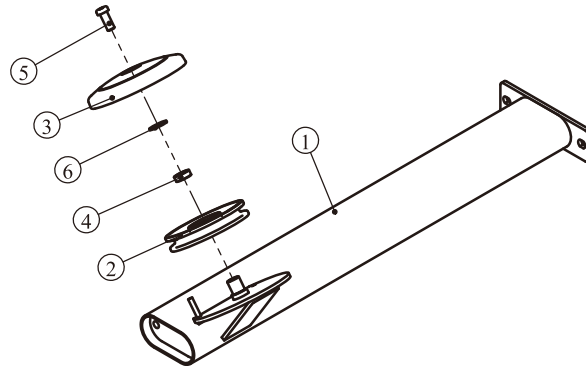

ItemNo.	Grade No.	Part No.	Description	QTY
1	6.1	IT95020500	Bottom Cross Brace	1
2	6.2	IT95057800	4.5" Pulley	1
3	6.3	IT95016400	Pulley Cover	1
4	6.4	FE97122100	Pulley Spacer 1	1
5	6.5	GB70BTM10*25DN18	Socket Head Cap Screw M10*25	1
6	6.6	DQ10N19B	Flat Washer $\Phi 11 * \Phi 25 * 2$	1

## FOAM Frame ASSY

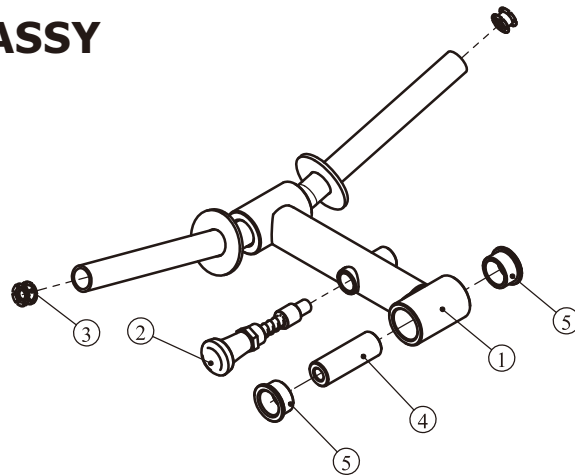

ItemNo.	Grade No.	Part No.	Description	QTY
1	7.1	IT95020600	FOAM Frame	1
2	7.2	IT95021600	Pin	1
3	7.3	IF81165000	Bolt	2
4	7.4	IT90021200V1	Axle $\Phi 25.4 * \Phi 12.5 * 72.5$	1
5	7.5	M02502000	Spacer $\Phi 38 * \Phi 32 * \Phi 25.4 * 18$	2

# Exploded View and Parts List

## Tension Cable ASSY

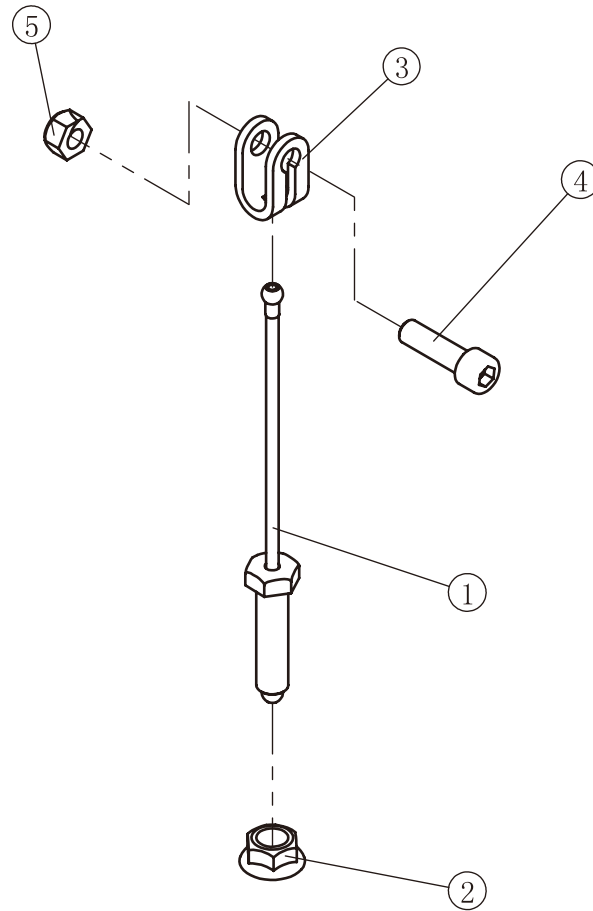

ItemNo.	Grade No.	Part No.	Description	QTY
1	10.1	IT95120801	Tension Cable	1
2	10.3	HF900-03A1002	Hex Flange Nut	1
3	10.5	BNH0562	Strap Bracket	1
4	10.6	GB70M10*35*15DN18	Socket Head Cap Screw M10*35	1
5	10.7	NM10DN2	Nylon Lock Nut M10	1

# Measurement Guide

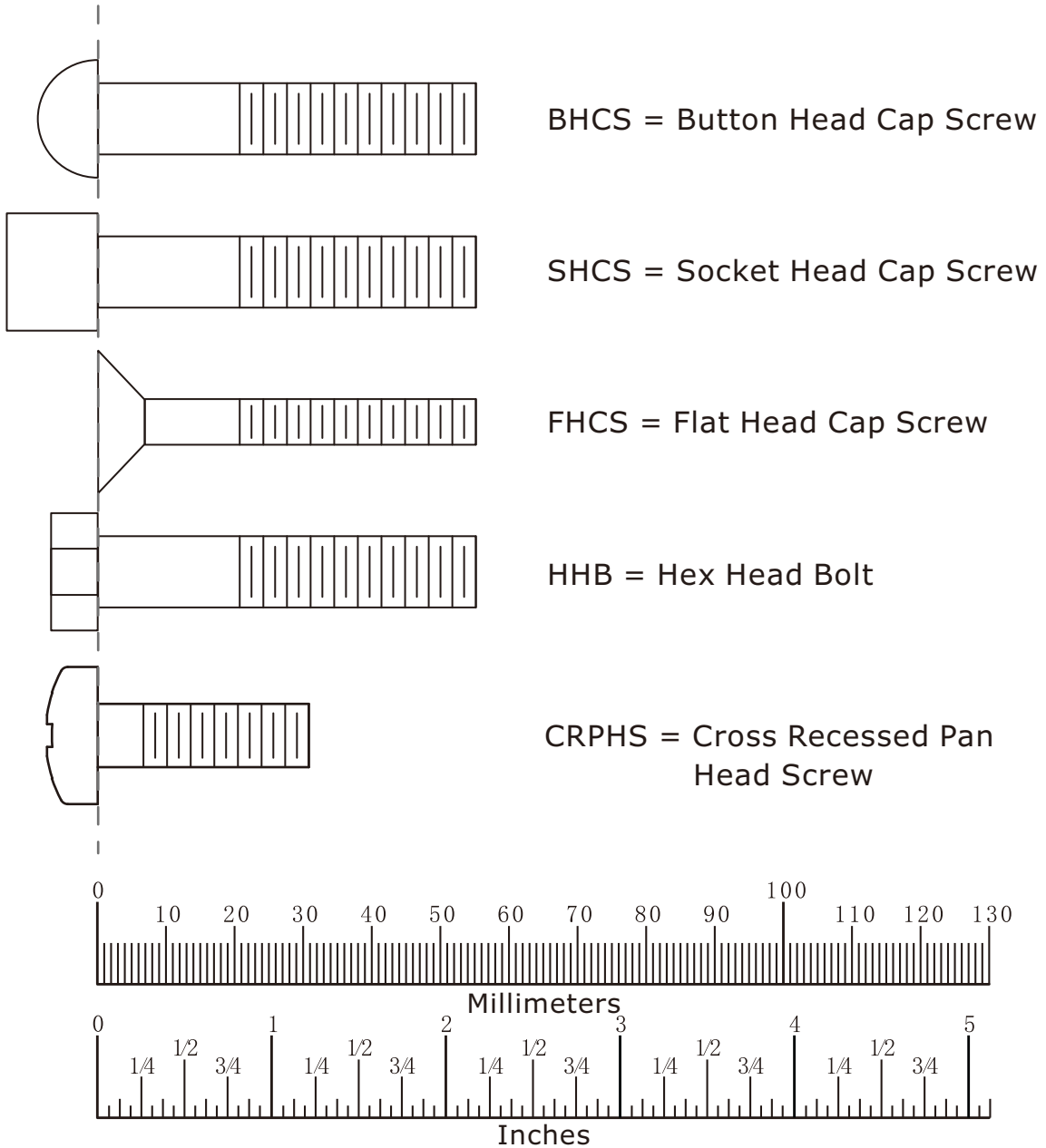

Diameter of bolt (mm/inch)	M6(1/4")	M8(5/16")	M10(3/8")	M12(1/2")	M16(5/8")
Tightening torque (N.m)	9~12	22~30	45~59	78~104	193~257
Operational methods for adult men	The strength of the wrist	The strength of the wrist and forearm	The strength of the entire arm	The strength of the arm and upper body	with all strength



# Assembly Instructions

Assembly of the equipment takes professional installers about 2 hours. If this is the first time you have assembled this type of equipment, plan to spend more time. It is strongly recommended to assemble the equipment by professional installers. You may find it quicker, safer, easier to assemble this equipment with the help of a friend, as some of components may be large, heavy or awkward to handle alone. It is important that you assemble your product in a clean, clear, uncluttered area. This will enable you to move around the product while you are fitting components and reduce the possibility of injury during assembly.

## **NOTE**

As with any assembled part, proper alignment and adjustment is critical. While tightening the fasteners, be sure to leave room for adjustments. Do not fully tighten the fasteners until instructed to do so. Be careful to assemble the components in the sequence presented in this guide.

# Assembly

## STEP 1

1. Attach two Adjustable Foot Plates (#12) to the Front Frame ASSY (#2).
2. Attach the Rear Bracket (#23) to the Top Rear Shroud (#55) using:  
two M6\*10 CRPHS (#123)
3. Attach the FOAM Frame ASSY (#7) to the Front Frame ASSY (#2) using:  
one M12\*105 SHCS (#112)  
two  $\Phi 13*\Phi 24*2.5$  Flat Washer (#124)  
one M12 Nylon Lock Nut (#127)

**Note: Wrench Tighten Bolts.**

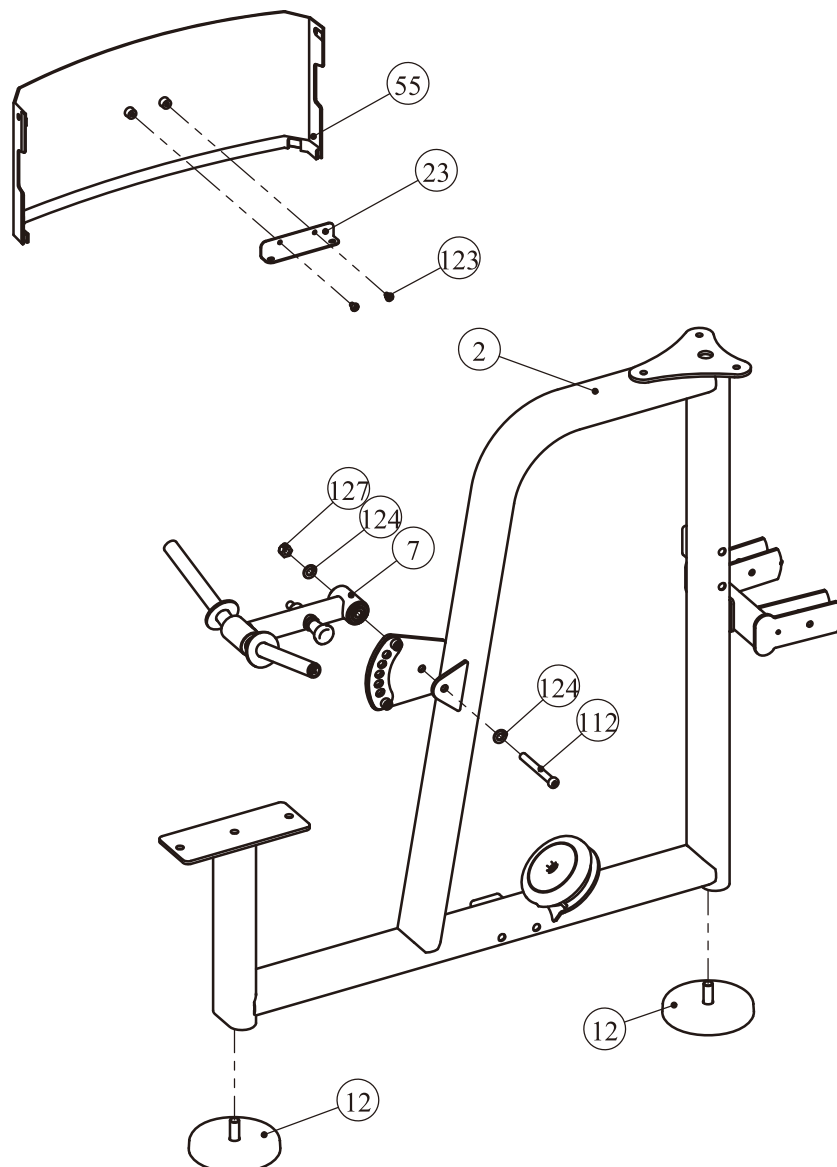

# Assembly

## STEP 2

Attach the Bottom Cross Brace ASSY (#6) and the Rear Connection Frame (#8) to the Weight Stack Frame ASSY (#1) and the Front Frame ASSY (#2) using:

- two Plastic Cover (#25)
- four M12\*135 SHCS (#111)
- two M12\*30 SHCS (#113)
- two M10\*80 SHCS (#114)
- two M10 Nylon Lock Nut (#128)
- four  $\Phi 11 \times \Phi 20 \times 2$  Flat Washer (#125)
- six  $\Phi 13 \times \Phi 24 \times 2.5$  Flat Washer (#124)

**Note: 1. Wrench Tighten Bolts and Nylon Lock Nuts.**

**2. Adjust the Adjustable Foot Plates to make the machines stable.**

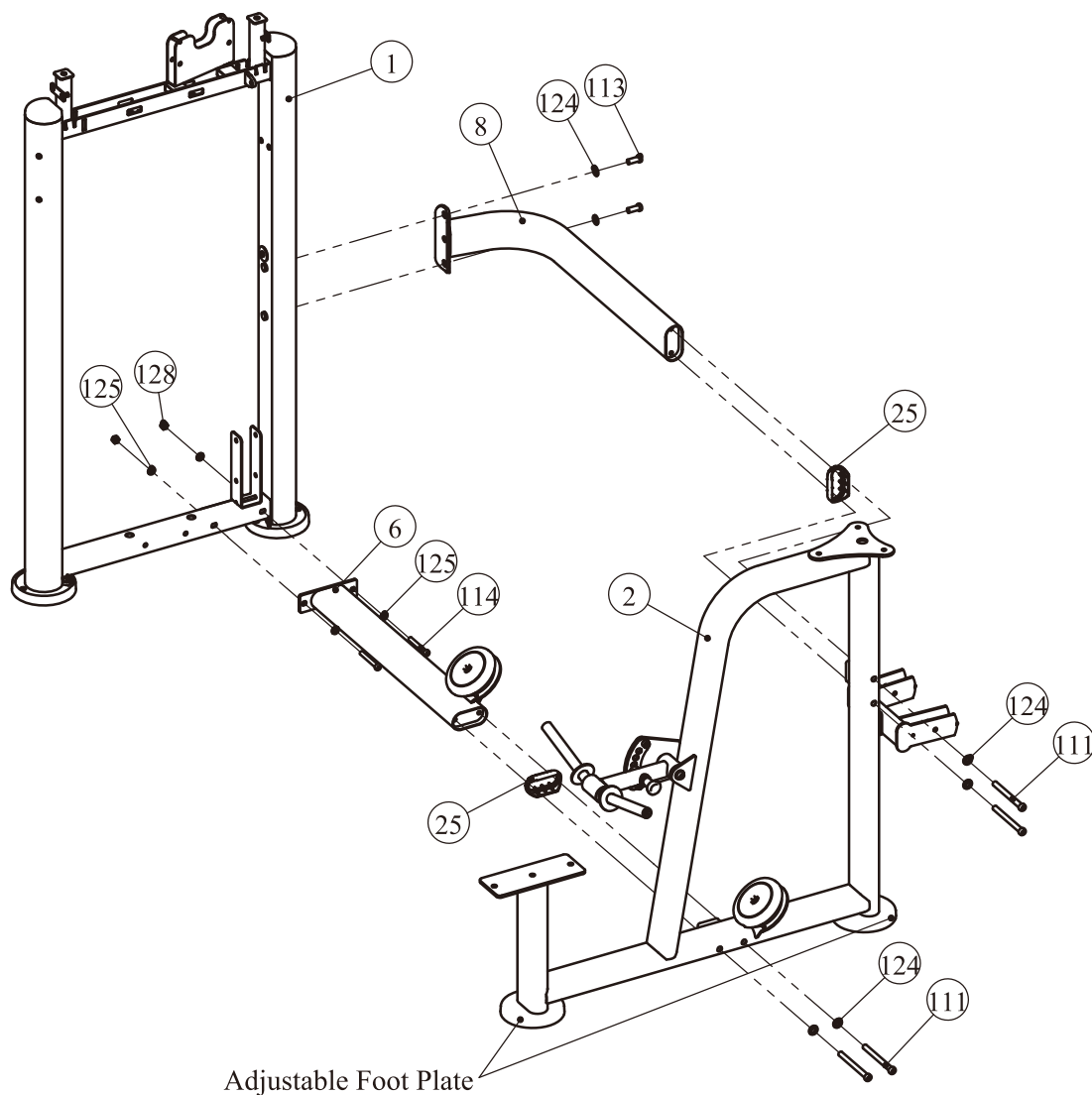

# Assembly

## STEP 3

1. Attach the Top Connection Frame ASSY (#3) to the Front Frame ASSY (#2) using:
  - one M10\*80 SHCS (#114)
  - two M10\*30 SHCS (#118)
  - six  $\Phi 11*\Phi 20*2$  Flat Washer (#125)
  - three M10 Nylon Lock Nut (#128)
2. Attach the Top Bracket ASSY (#21) and two Bottom Bracket ASSY (#22) to the Weight Stack Frame ASSY (#1) using:
  - two M8\*20 SHCS (#120)
  - two  $\Phi 9*\Phi 16*1.6$  Flat Washer (#126)
  - two M10\*75 SHCS (#115)
  - four  $\Phi 11*\Phi 20*2$  Flat Washer (#125)
  - two M10 Nylon Lock Nut (#128)

**Note: Wrench Tighten Bolts and Nylon Lock Nuts.**

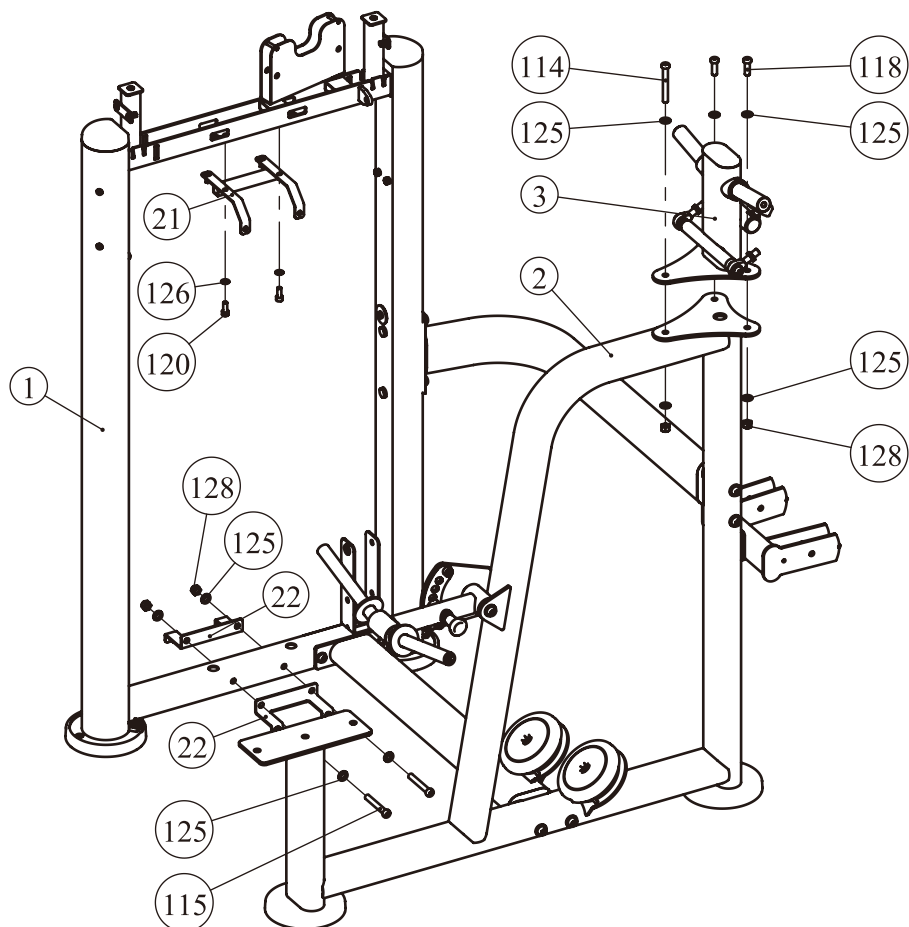

# Assembly

## STEP 4

1. Attach the Right Arm Frame ASSY (#4) and Left Arm Frame ASSY (#5) to the Top Connection Frame ASSY (#3) using:

two Cap  $\Phi 60$  (#103)

two Circle Ring  $\Phi 62.5 \times 5$  (#104)

two M10\*25 SHCS (#119)

2. Attach three 4.5" Pulleys (#28) to the Weight Stack Frame ASSY (#1) using:

two M10\*75 SHCS (#115)

four  $\Phi 11 \times \Phi 20 \times 2$  Flat Washer (#125)

one Pulley Spacer (#107)

two M10 Nylon Lock Nut (#128)

**Note: 1. Wrench tighten bolts and Nylon Lock Nuts.**

**2. Adjust the Urethane Bumper on the Right Arm Frame ASSY (#4) and Left Arm Frame ASSY (#5), to make sure the two handle bars on the same height.**

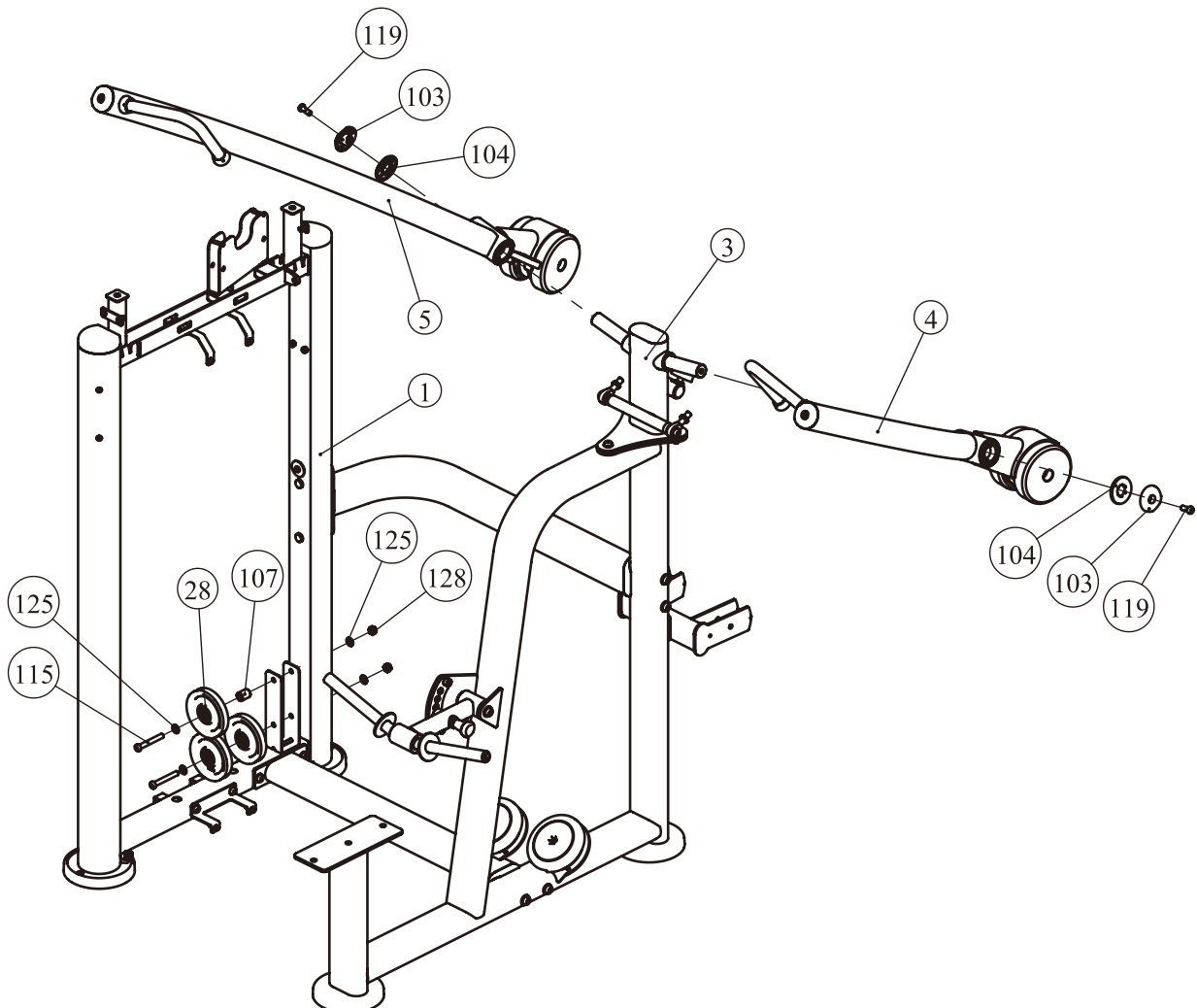

# Assembly

## STEP 5

Here is the assembly instruction for **160LBS Weights !**

### 1. Attach:

- two Guide Rod  $\Phi 19 \times 1242$  (#44)
- two Weight Rubber Bumper (#105)
- fifteen Weight Plate 10LBS (#63)
- two weight stack space (#64)
- one Top Plate (#42)

to the Weight Stack Frame ASSY (#1) using:

- two Guide Rod Fixing Sleeve  $\Phi 25 \times \Phi 19 \times 45$  (#108)
- two Spring (#110)

2. Attach the Selector Pin W/Coil (#106) to the Top Plate (#42).

3. Attach the Split Pin (#133) to the Weight Plate 10LBS (#63).

Grade No.	Part No.	Description	QTY
63	FE97193100	10LBS Weight Plate	15
64	FEWS01ASSY	Weight Stack Space	2

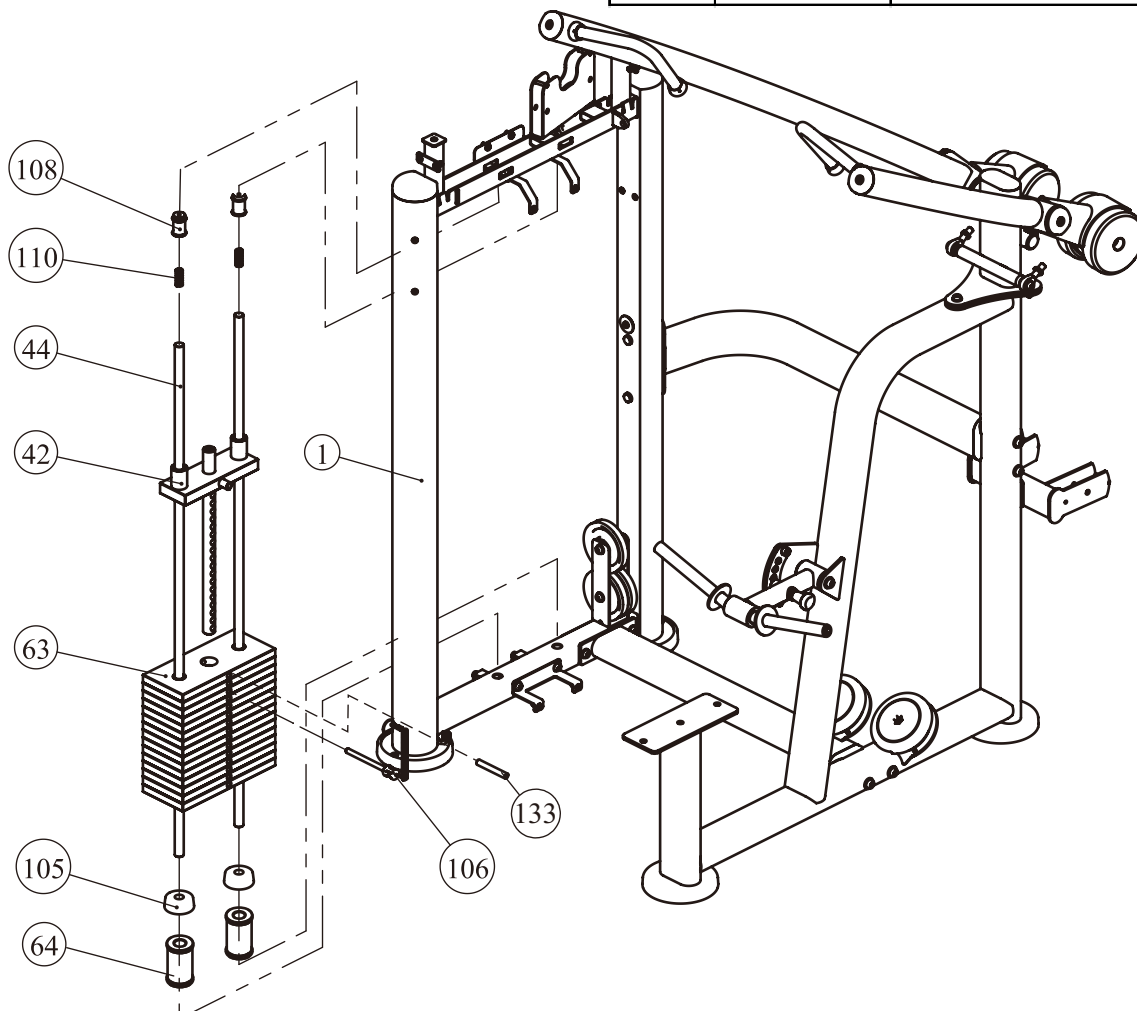

# Assembly

## STEP 5

Here is the assembly instruction for **200LBS Weights !**

1. Attach:

- two Guide Rod  $\Phi 19 \times 1242$  (#44)
- two Weight Rubber Bumper (#105)
- nineteen Weight Plate 10LBS (#63)
- one Top Plate (#42)

to the Weight Stack Frame ASSY (#1) using:

- two Guide Rod Fixing Sleeve  $\Phi 25 \times \Phi 19 \times 45$  (#108)
- two Spring (#110)

2. Attach the Selector Pin W/Coil (#106) to the Top Plate (#42).

3. Attach the Split Pin (#133) to the Weight Plate 10LBS (#63).

Grade No.	Part No.	Description	QTY
63	FE97193100	10LBS Weight Plate	19

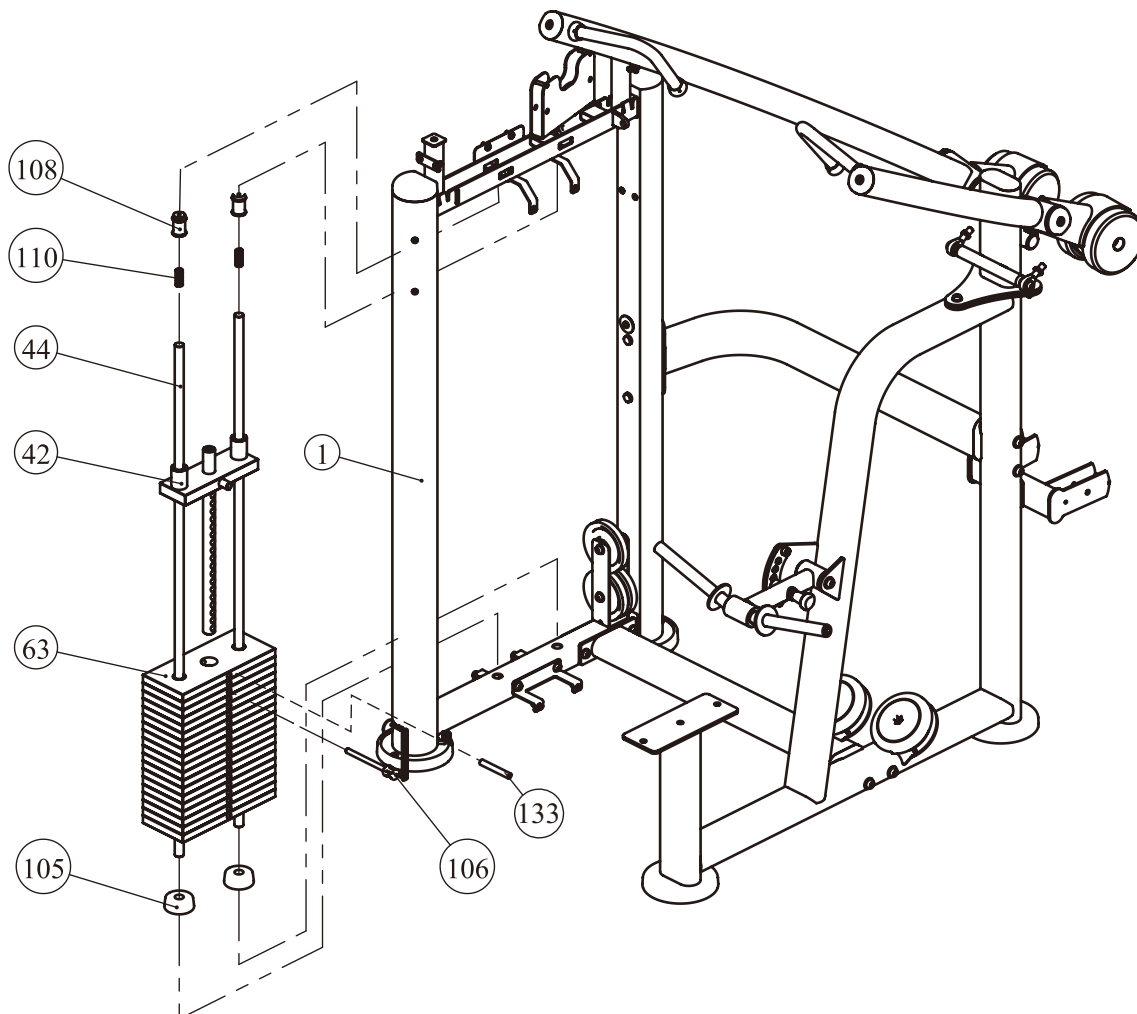

# Assembly

## STEP 5

Here is the assembly instruction for **235LBS Weights !**

### 1. Attach:

- two Guide Rod  $\Phi 19 \times 1242$  (#44)
- two Weight Rubber Bumper (#105)
- fifteen Weight Plate 15LBS (#65)
- two weight stack space (#64)
- one Top Plate (#42)

to the Weight Stack Frame ASSY (#1) using:

- two Guide Rod Fixing Sleeve  $\Phi 25 \times \Phi 19 \times 45$  (#108)
- two Spring (#110)

2. Attach the Selector Pin W/Coil (#106) to the Top Plate (#42).

3. Attach the Split Pin (#133) to the Weight Plate 15LBS (#65).

Grade No.	Part No.	Description	QTY
65	FE97193200	15LBS Weight Plate	15
64	FEWS01ASSY	Weight Stack Space	2

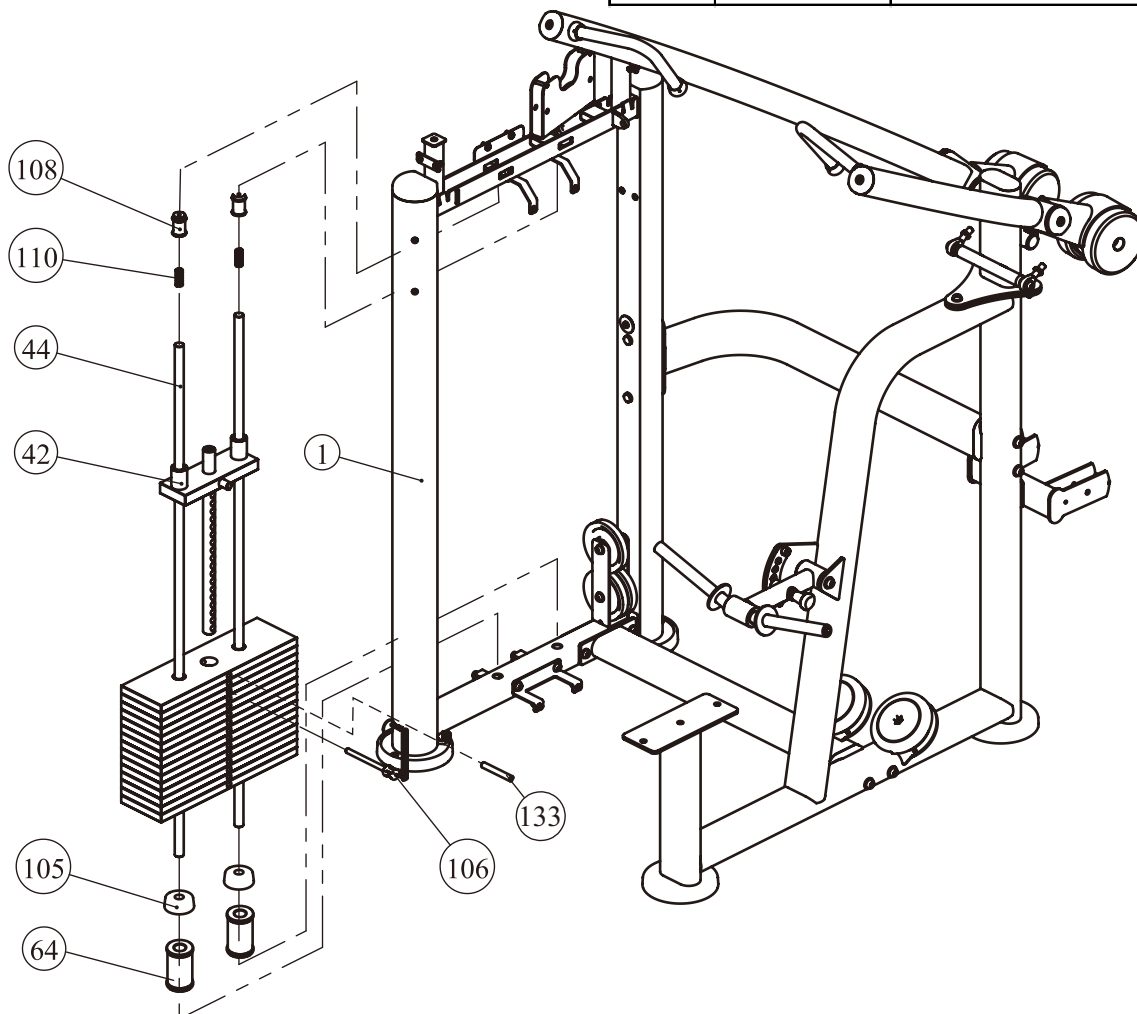



# Assembly

## STEP 5

Here is the assembly instruction for **295LBS Weights !**

### 1. Attach:

- two Guide Rod  $\Phi 19 \times 1242$  (#44)
- two Weight Rubber Bumper (#105)
- nineteen Weight Plate 15LBS (#65)
- one Top Plate (#42)

to the Weight Stack Frame ASSY (#1) using:

- two Guide Rod Fixing Sleeve  $\Phi 25 \times \Phi 19 \times 45$  (#108)
- two Spring (#110)

2. Attach the Selector Pin W/Coil (#106) to the Top Plate (#42).

3. Attach the Split Pin (#133) to the Weight Plate 15LBS (#65).

Grade No.	Part No.	Description	QTY
65	FE97193200	15LBS Weight Plate	19

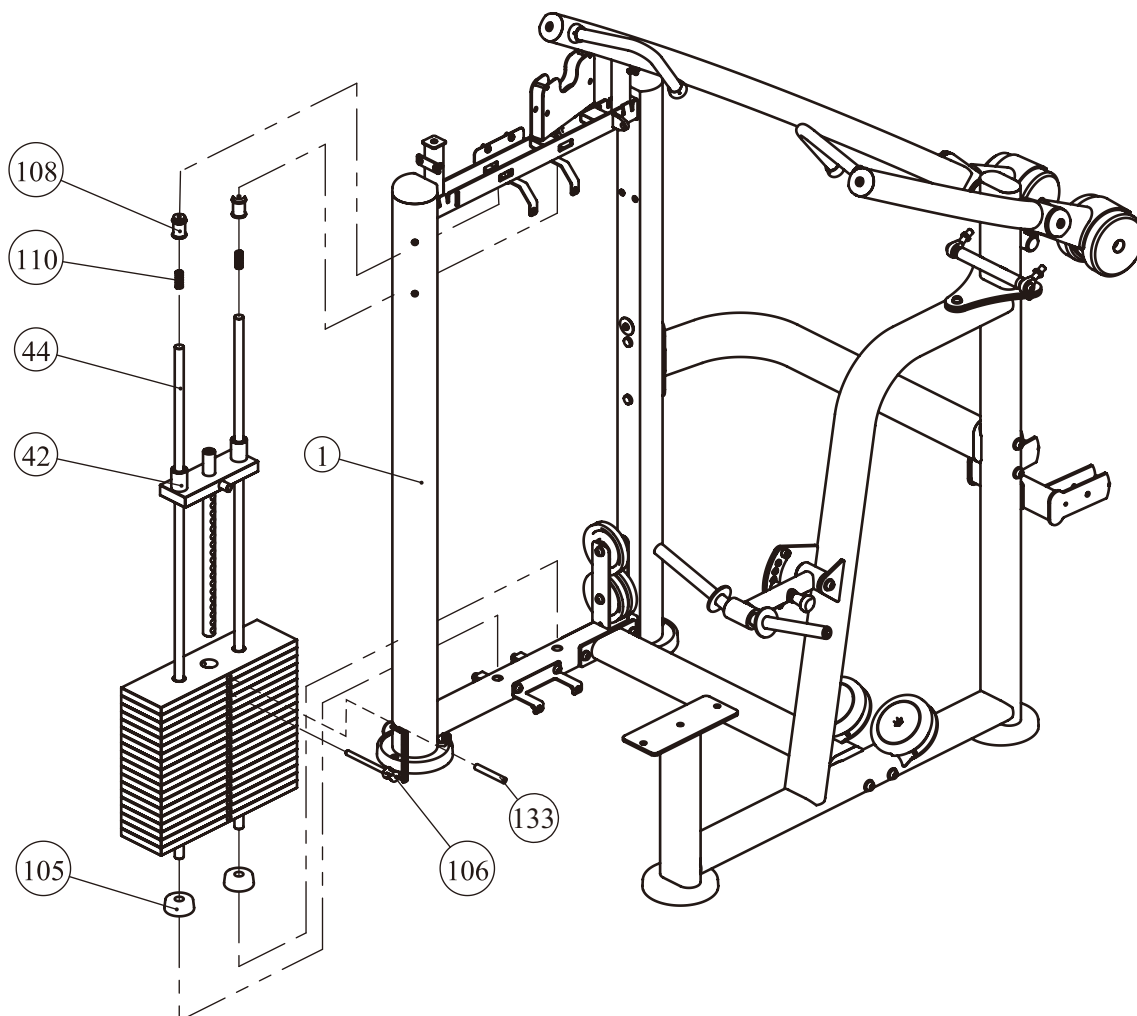

# Assembly

## All weight plate sticker paste schematic diagram

LBS 20	9
LBS 30	14
LBS 40	18
LBS 50	23
LBS 60	27
LBS 70	32
LBS 80	36
LBS 90	41
LBS 100	45
LBS 110	50
LBS 120	54
LBS 130	59
LBS 140	64
LBS 150	68
LBS 160	73
LBS 170	77
LBS 180	82
LBS 190	86
LBS 200	91
LBS 210	95
LBS 220	100
LBS 230	104

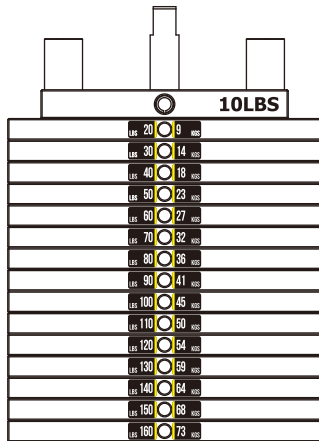

20-160LBS

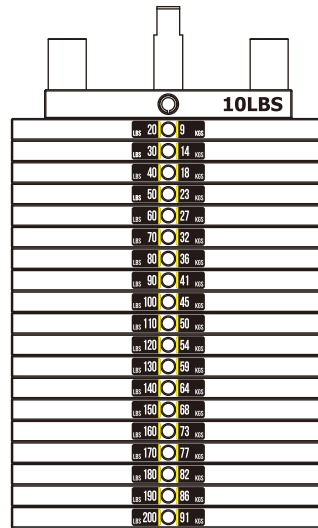

20-200LBS

LBS 25	11
LBS 40	18
LBS 55	25
LBS 70	32
LBS 85	38
LBS 100	45
LBS 115	52
LBS 130	59
LBS 145	66
LBS 160	72
LBS 175	79
LBS 190	86
LBS 205	93
LBS 220	100
LBS 235	107
LBS 250	113
LBS 265	120
LBS 280	127
LBS 295	134
LBS 310	141
LBS 325	147

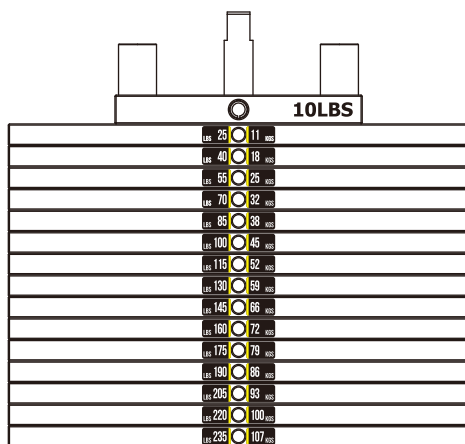

25-235LBS

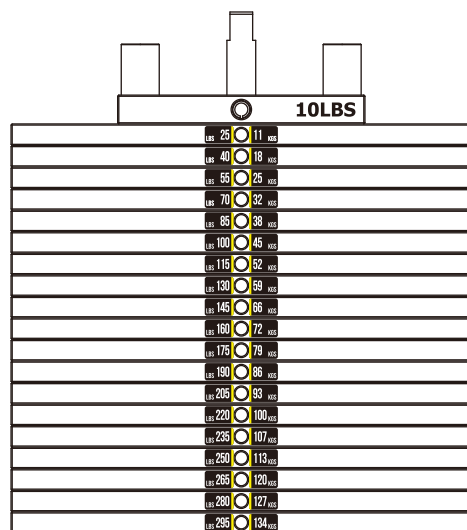

25-295LBS

# Assembly

## STEP 6

1. Attach two 4.5" Pulleys (#28) to the Weight Stack Frame ASSY (#1) using:  
two M10\*50 SHCS (#117)                      four  $\Phi 11*\Phi 20*2$  Flat Washer (#125)  
two M10 Nylon Lock Nut (#128)
2. Attach two 4.5" Pulleys (#28) to the Double Pulley Bracket (#24) using:  
two M10\*50 SHCS (#117)                      four  $\Phi 11*\Phi 20*2$  Flat Washer (#125)  
two M10 Nylon Lock Nut (#128)
3. Take down one M10 Nylon Lock Nut and one M10\*35 SHCS from the Tension Cable ASSY (#10), Attach the Tension Cable ASSY (#10) to the Top Plate (#42) and the Weight Stack Frame ASSY (#1) using:  
one M10 Nylon Lock Nut (Down off)      one M10\*35 SHCS (Down off)
4. Make the DIP Cable (#9) through the 4.5" Pulleys on Weight Stack Frame ASSY (#1), the 4.5" Pulleys on the Double Pulley Bracket (#24), the 4.5" Pulleys on Bottom Cross Brace ASSY (#6), the 4.5" Pulleys on Front Frame ASSY (#2), Then attach to the Right Arm Frame ASSY (#4) and the Left Arm Frame ASSY (#5) using:  
two Cable Connector (#102)                      two Cable Connector Jacket (#101)

**Note: Wrench tighten bolts and Nylon Lock Nuts.**

## Step 7

**Tips:** Pre-assemble the 8 bolts into the Weight Stack Frame ASSY and Bottom Bracket ASSY, not wrench tighten Bolts, Assemble the shroud with the bolts on. Then wrench tighten Bolts.

1. Attach the Front Shroud (#53) and the Right Front Shroud (#54) to the Weight Stack Frame ASSY (#1) and the Bottom Bracket ASSY (#22) using:  
four M6\*20 CRPHS (#121)                      two M6\*16 CRPHS (#122)
2. Attach the Rear Shroud (#56) to the Weight Stack Frame ASSY (#1) and the Bottom Bracket ASSY (#22) using:  
four M6\*20 CRPHS (#121)                      two M6\*16 CRPHS (#122)
3. Attach the Training Placard Cover (#52) to the Weight Stack Frame ASSY (#1) and the Top Bracket ASSY (#21) using:  
two M6\*20 CRPHS (#121)                      two M6\*10 CRPHS (#123)
4. Attach the Top Rear Shroud (#55) to the Weight Stack Frame ASSY (#1) and the Top Bracket ASSY (#21) using:  
four M6\*20 CRPHS (#121)
5. Attach the Top Cover (#51) to the Weight Stack Frame ASSY (#1) using:  
two M6\*20 CRPHS (#121)                      two Spout Plug  $\Phi 16.5*6.88$  (#109)
6. Attach the Cup Holder (#92) to the Weight Stack Frame ASSY (#1) using:  
two M6\*20 CRPHS (#121)

# Assembly

## STEP 6

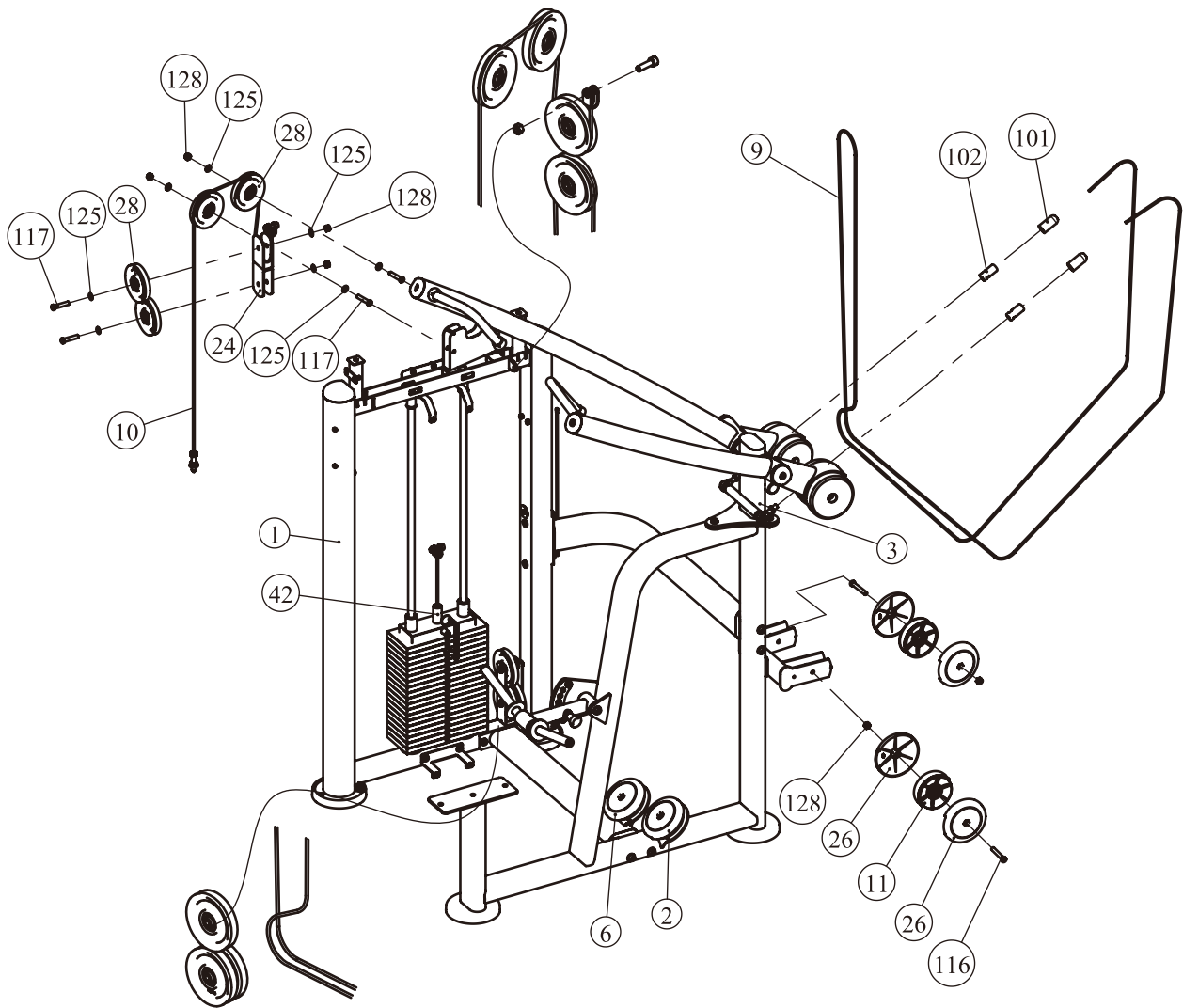

# Assembly

## STEP 7

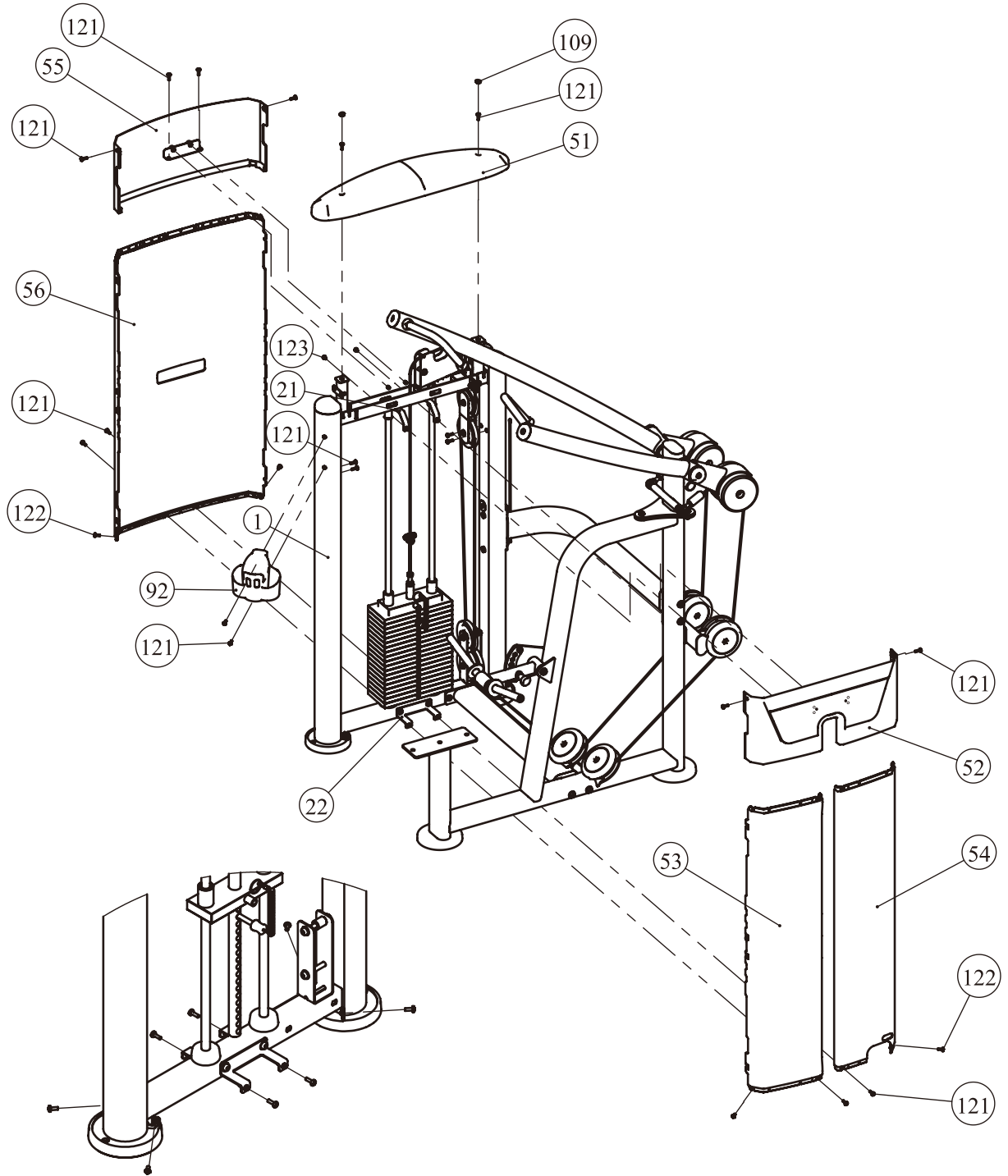

# Assembly

## STEP 8

1. Attach the Seat Pad (#76) to the Front Frame ASSY (#2) using:
  - two M10\*30 SHCS (#118)
  - two  $\Phi 11*\Phi 20*2$  Flat Washer (#125)
2. Attach the two Shot FOAM ASSY (#31) to the FOAM Frame ASSY (#7) using:
  - two Cap  $\Phi 60$  (#103)
  - two Circle Ring  $\Phi 62.5*5$  (#104)
  - two M10\*25 SHCS (#119)

**Note: Wrench tighten bolts and Nylon Lock Nuts.**

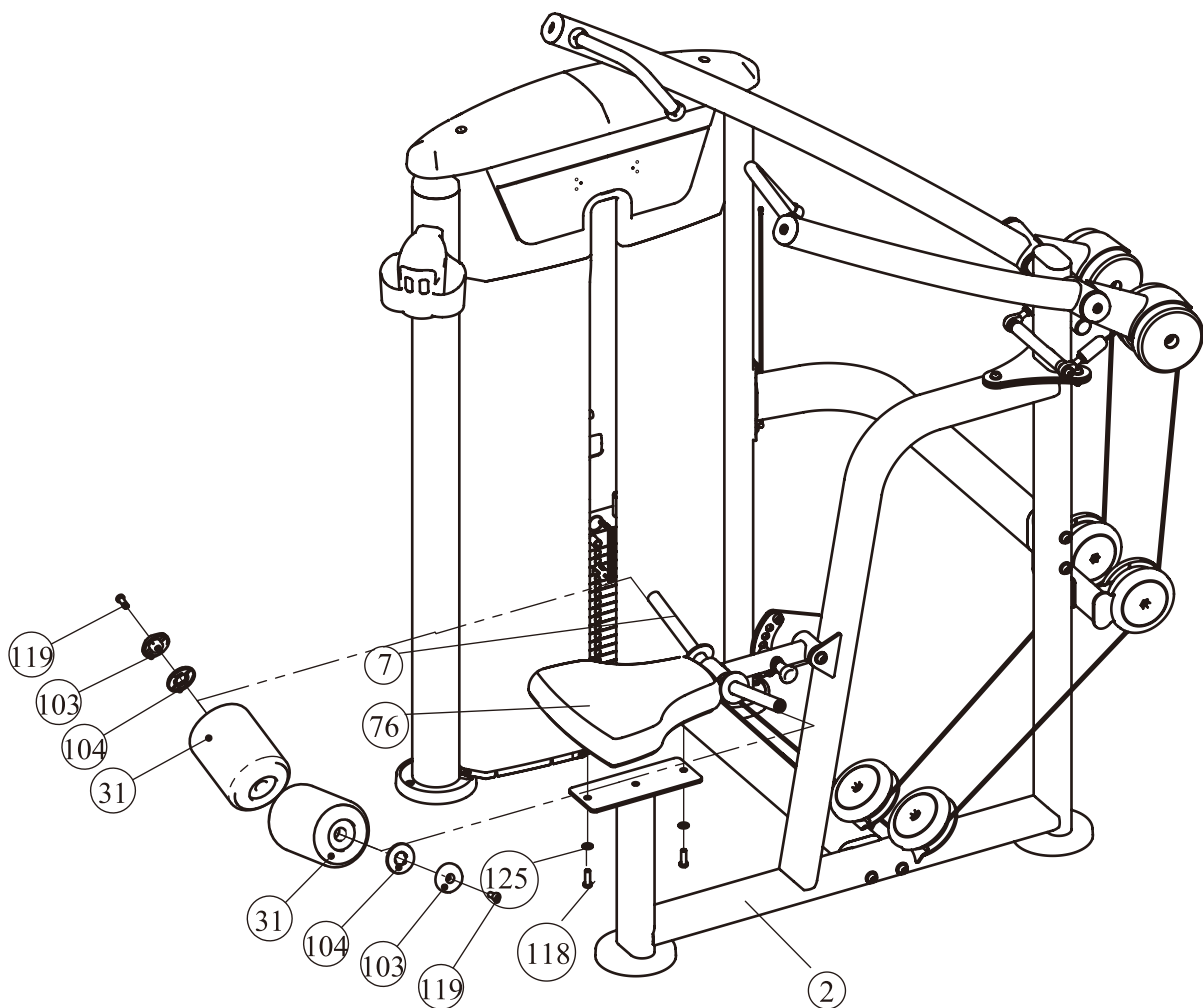

# Adjust Instructions

## The Use Position adjustment

1. Pull the Adjustable Support and adjust the Shot FOAM ASSY to the desired position.
2. Make sure the pin gets into the hole completely.

## The use of Selector Pin W/Coil

1. Select an appropriate weight and put the Selector Pin W/Coil into the hole on it.
2. Make sure the Selector Pin W/Coil gets into the hole completely.

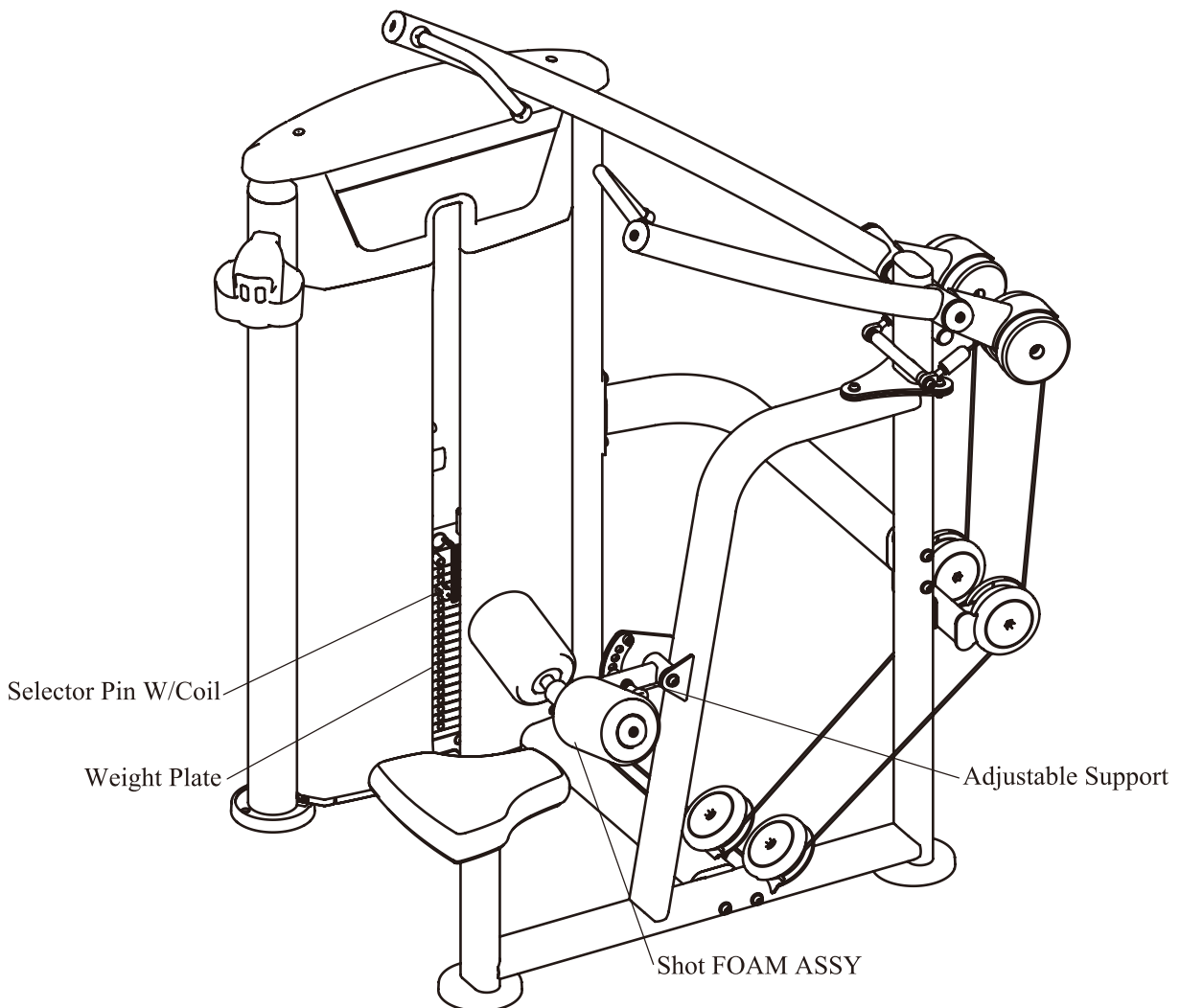

# Exercise Instructions

## LAT PULL

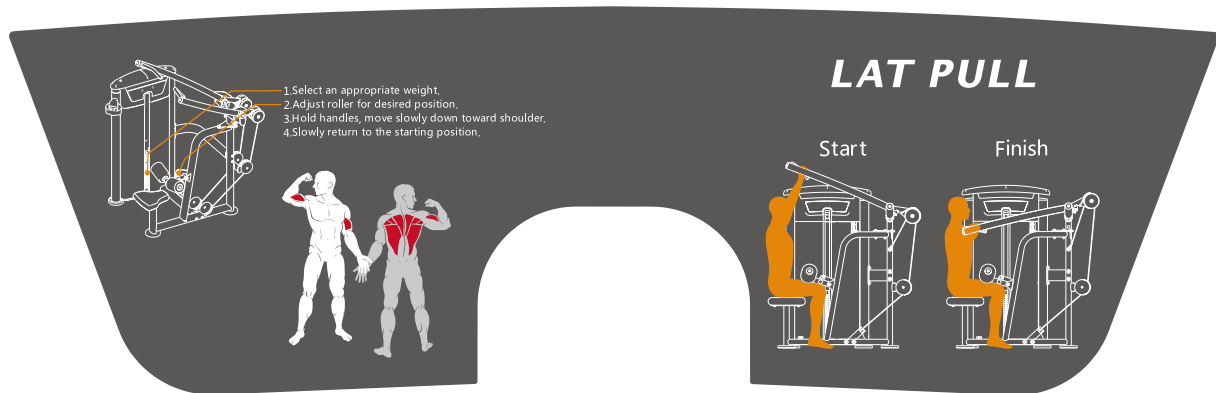

1. Select an appropriate weight.  
2. Adjust roller for desired position.  
3. Hold handles, move slowly down toward shoulder.  
4. Slowly return to the starting position.

Start      Finish

This block contains a diagram of the lat pull machine with four numbered instructions. To the right, two anatomical diagrams of a human torso show the latissimus dorsi muscle highlighted in red. Below the instructions, two orange silhouettes of a person sitting on the machine illustrate the 'Start' and 'Finish' positions of the exercise.

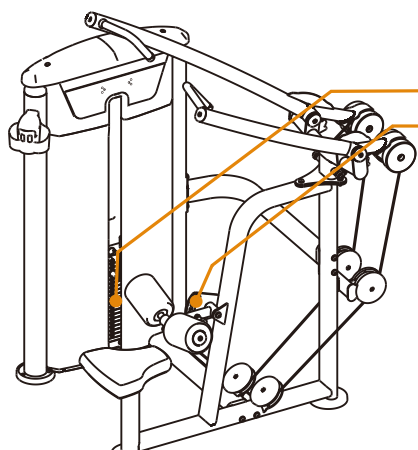

1. Select an appropriate weight.  
2. Adjust roller for desired position.  
3. Hold handles, move slowly down toward shoulder.  
4. Slowly return to the starting position.

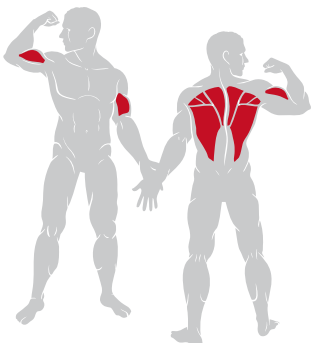

This block features a detailed line drawing of the lat pull machine's pulley and handle system. To the right, two anatomical diagrams of a human torso show the latissimus dorsi muscle highlighted in red.

Start      Finish

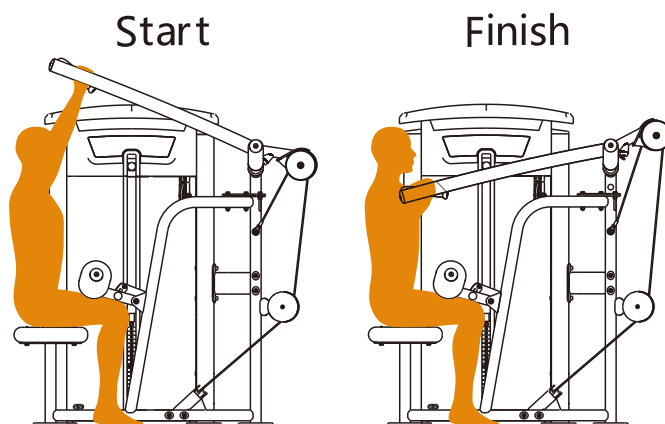

This block shows two orange silhouettes of a person sitting on the lat pull machine. The first silhouette is labeled 'Start' and shows the person with their arms extended upwards, holding the handles. The second silhouette is labeled 'Finish' and shows the person pulling the handles down towards their shoulders.



# Maintenance Schedule

ROUTINE	COMMERCIAL MAINTENANCE	HOME MAINTENANCE	LATEST DATE ENTRY					
Inspect; Links, Pull Pins, Snap Locks, Swivels, Weight Stack Pins	DAILY	WEEKLY						
Clean; Upholstery	DAILY	WEEKLY						
Inspect; Cables or Belts and their tension	DAILY	WEEKLY						
Inspect; Accessory Bars, and Handles	WEEKLY	3 MONTHS						
Inspect; All Decals	WEEKLY	3 MONTHS						
Inspect; All Nuts and Bolts, Tighten if needed	WEEKLY	3 MONTHS						
Inspect; Anti-Skid Surface	WEEKLY	3 MONTHS						
Clean & Lubricate; Guide Rods with a Teflon (PTFE) based lubricant (Superlube)	MONTHLY	3 MONTHS						
Lubricate; Seat Sleeves, Turcite Bushings, Linear Bearing	MONTHLY	3 MONTHS						
Clean and Wax; All Glossy Finishes	6 MONTHS	YEARLY						
Repack with Grease; Linear Bearings	6 MONTHS	YEARLY						
Replace; Cables, Belts and Connecting Parts	YEARLY	3 YEARS						

*Your equipment comes with a commercial maintenance decal. For personal, in home use, please follow the home maintenance schedule listed above.*

# General Maintenance Information

## **Links, Pull-Pins, Snap Hooks, Swivels, Weight Stack Pins:**

- \* Check all pieces for signs of visible wear or damage.
- \* Check springs in snap hooks and pull-pins for proper tension and alignment.
- \* If the spring sticks or has lost its rigidity, replace it immediately.

## **Upholstery:**

- \* To ensure prolonged upholstery life and proper hygiene, all upholstered pads should be wiped down with a damp cloth after every workout.
- \* Periodically take the time to use a mild soap or an approved vinyl upholstery cleaner to deter the onset of cracking or drying. Avoid using any abrasive cleaners or cleaners not intended for use on vinyl.
- \* Replace ripped or worn upholstery immediately.
- \* Keep sharp or pointed objects clear of all upholstery.

## **Decals:**

- \* Inspect and familiarize yourself with any safety warnings or other user information posted on each decal.

## **Nuts and Bolts:**

- \* Inspect all nuts and bolts for any loosening and tighten if needed.
- \* Go through a re-tightening sequence periodically to ensure that all hardware is tensioned proper.

## **Anti-Skid Surfaces:**

- \* These surfaces are designed to supply secure footing and need to be replaced if they appear worn or become slippery.

## **Belts and Cables:**

- \* We use only high quality belt, and mil-spec cables.
- \* Visually inspect the belts and cables for fraying, cracking, peeling or discoloration.
- \* While the machine is not in use, carefully run your fingers along the belt or cable to feel for thinning or bulging areas.
- \* Replace belts and cables immediately at the first signs of damage or wear. Do not use equipment until belts or cables have been replaced.

## **Belt and Cable Tension:**

- \* Referring to the Owners Manual, when belts or cables are used check all bolt attachments to be sure they are properly attached.
- \* Check slack in cables and re-adjust cable tension if needed.

## **Seat Sleeves, Guide Rods:**

- \* Wipe down adjusting tubes with a dust free rag before applying lubricant.
- \* Lubricate seat sleeves and Guide Rods with a Silicon or Teflon based lubricant spray.

## **Linear Bearings:**

- \* Referring to the Owners Manual carefully disassemble the bearing from its housing and place a finger full of light grease (lithium, super lube, etc.) into the inside of the bearing. Using your finger, press the grease into the ball-bearings and their tracks. Repeat until the ball-bearing tracks are full of grease. Insert the shaft back into the bearing and wipe off excess grease.

**PLEASE KEEP THIS FOR YOUR RECORDS**

## Weight Training Tips

Use this manual to guide you through the basic exercises you can perform on your equipment. To gain maximum results and avoid possible injury, consult a fitness professional to develop your complete exercise program.

Always consult your physician before starting any exercise program.

To be successful in your exercise program, it is important to develop an understanding of the basic principles of strength training. Now that you have your equipment, it is only natural that you want to get started immediately. First, determine a set of realistic goals and objectives for yourself. By deciding on an exercise plan that is right for you prior to starting, you will contribute significantly to your success.

Warm up properly before engaging in weight resistance training. Stretching, yoga, jogging, calisthenics or other cardiovascular exercise can help prepare your body for the heavier workload of lifting weights.

Learn how to perform the exercise correctly before using heavy weight. Correct form is important to avoid injury and to ensure that you work the proper muscle groups.

Know your limitations. If you are new to weight training or are embarking on an exercise regimen after a long layoff, start slowly and build foundational strength over a longer period of time.

Pay attention to your breathing. Exhale when you exert is a general rule of thumb. Never hold your breath.

